



AZURI[®]

SERVICE MANUAL



DELTRON[®]

CONTENTS

Part I : Technical Information	1
1. Summary	1
1-1 Appearance.....	1
1-2 Model List.....	2
2. Outline Dimension Diagram	2
2-1 Indoor Unit	2
2-2 outdoor Unit	6
3. Specification sheet	7
4. Refrigerant System Diagram	11
4-1 Cooling Only	11
4-2 Cooling & Heating.....	12
5. Electrical Part	14
Part II : Installation and Maintenance	15
6. Main Tools for Installation and Maintenance	15
7. Installation	16
7-1 Notes for Installation	16
7-2 Installation of Indoor Unit.....	17
7-3 Installation of outdoor Unit	20
7-4 Check after installation and test operation	22
8. Maintenance	24
9-1 Troubleshooting Guide	24
9-2 Troubleshooting for Normal Malfunction.....	52
9. Removal Procedure	59
10-1 Indoor Unit	59
10-2 Outdoor Unit.....	64

Part I : Technical Information

1. Summary

1-1 Appearance

Indoor Unit



Outdoor Unit

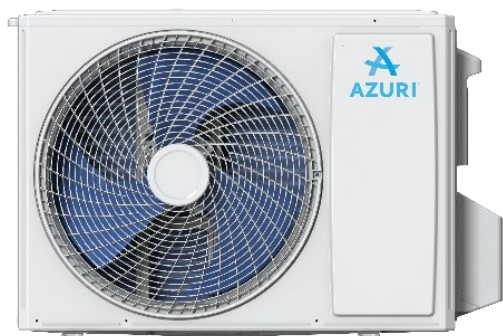

Note: The outdoor grille can be replaced.

1-2 Model List

NO.	MODEL	NO.	MODEL
1	AZI-WK25XA/I + AZI-WK25XA/O	2	AZI-WK35XA/I + AZI-WK35XA/O
3	AZI-WK50XA/I + AZI-WK50XA/O	4	AZI-WK70XA/I + AZI-WK70XA/O

2. Outline Dimension Diagram

The following data is for reference only and the actual size may vary.

2-1 Indoor Unit (Unit: mm)

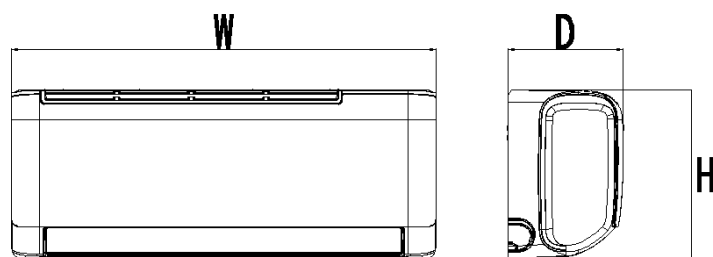

Dimension W*H*D (mm)
761*296*199
960*315*221
1089*328*227

25/35:

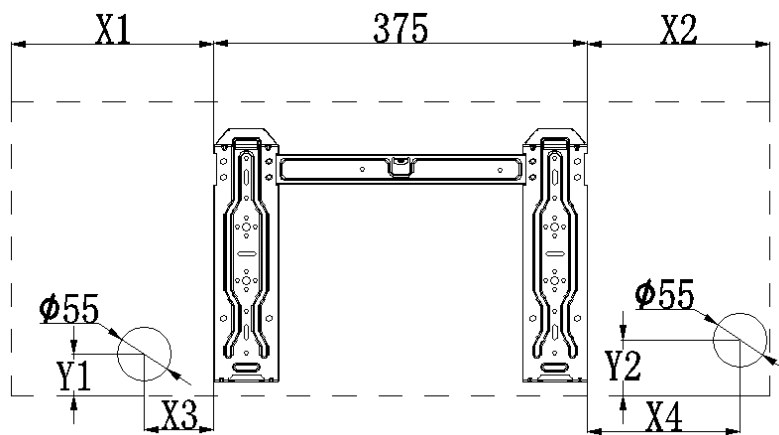

Dimension					
X1	X2	X3	X4	Y1	Y2
203	183	70	153	42	56

50:

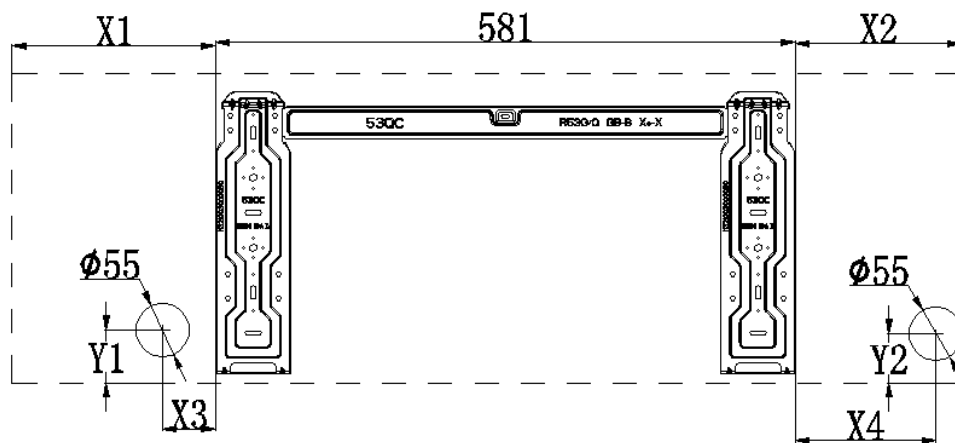

Dimension					
X1	X2	X3	X4	Y1	Y2
208	170	54	141	49	50

70:

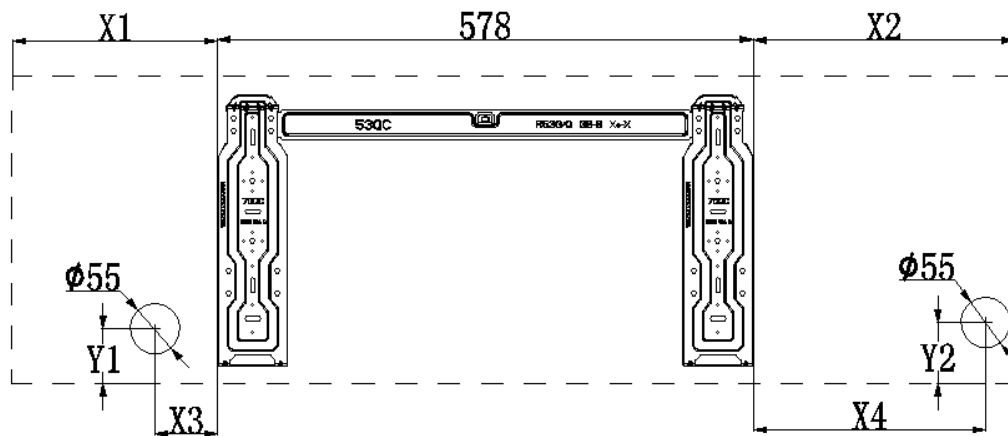

Dimension					
X1	X2	X3	X4	Y1	Y2
225	286	68	251	49	60

25/35:

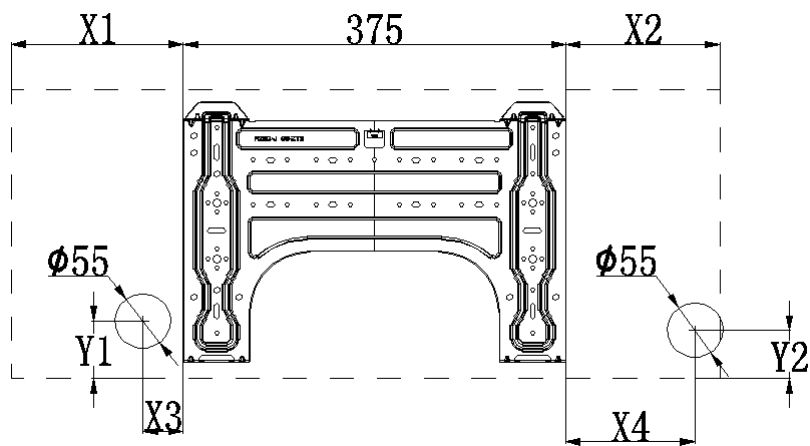

Dimension					
X1	X2	X3	X4	Y1	Y2
203	183	70	153	42	56

50:

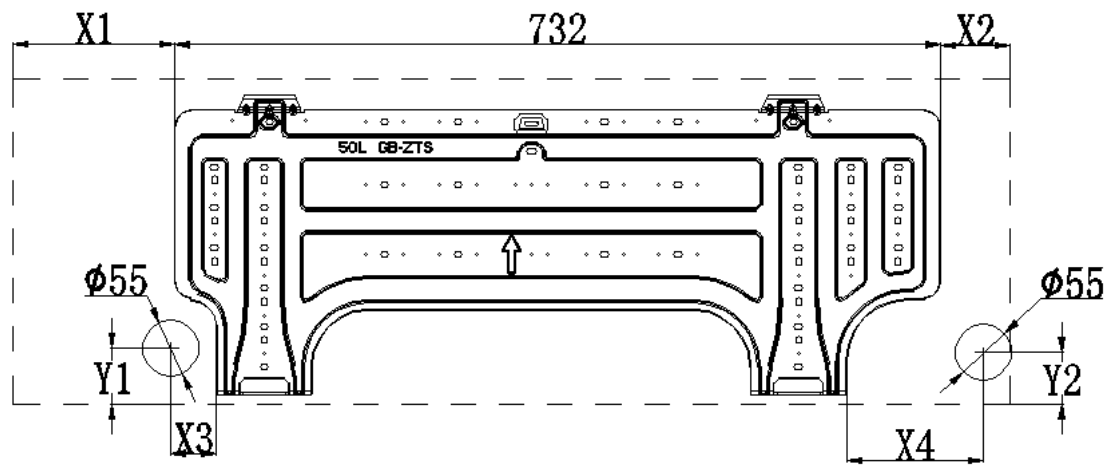

Dimension					
X1	X2	X3	X4	Y1	Y2
158	70	43	131	49	50

70:

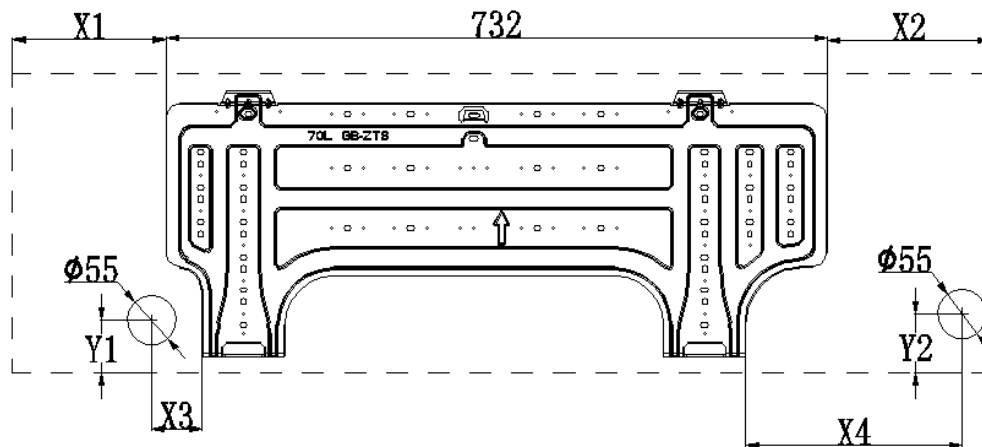

Dimension					
X1	X2	X3	X4	Y1	Y2
173	184	56	239	49	60

2-2 outdoor Unit (Unit: mm)

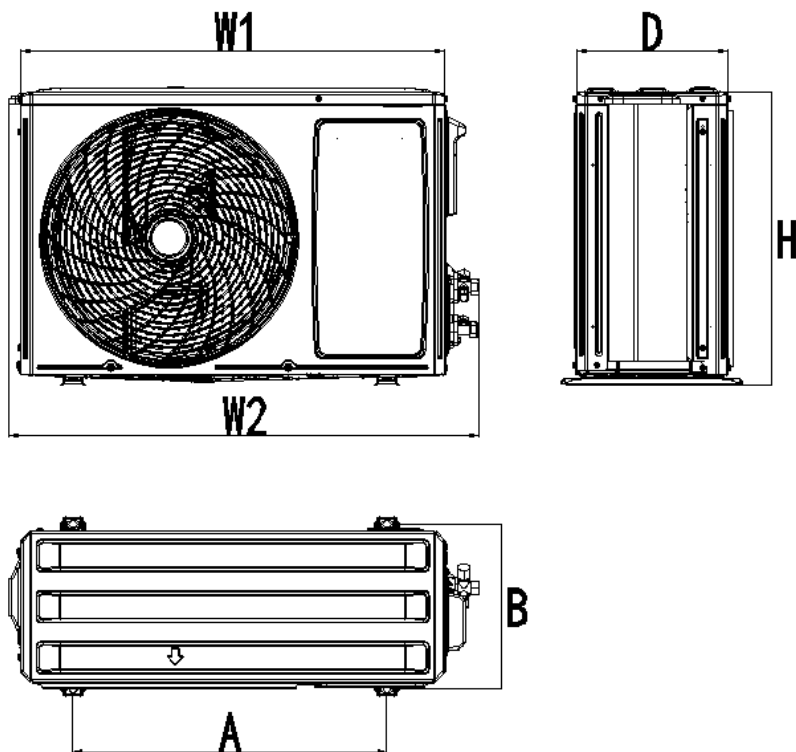

Model	Dimension W1(W2)*H*D (mm)	A (mm)	B (mm)
25/35	705(780)*530*258	480	283
50	785(867)*548*281	545	315
70	900(965)*695*319	630	350

3. Specification sheet

Product Model				AZI-WK25XA/I + AZI-WK25XA/O	
Nameplate Parameter	Rated Capacity	Cooling		W	2700
		Heating		W	3000
		Dehumidifying		Kg/h	0.8
	Rated Power Consumption	Cooling		W	830
		Heating		W	800
	Rated Running Current	Cooling		A	3.9
		Heating		A	3.7
	Electric heating power			W	39
	Max. Input Power			W	1800
	Max. Input Current			A	9.5
	EER Cooling			W/W	6.2
	COP Heating			W/W	4.0
	Power supply source			V/Ph/Hz	220-240V-1-50Hz
	Refrigerant				R32
	Refrigerant Charged			g	550
	Max. Discharge Pressure			Mpa	4.3MPa
	Max. Suction Pressure			Mpa	2.5MPa
	Air Flow Volume			m ³ /h	620
	Noise level			dB (A)	54
	Noise level			dB (A)	61
Indoor unit weight (Net)			Kg	7.3	
Outdoor unit weight (Net)			Kg	21.5	
Indoor unit configuration	evaporator	Tube	Length	mm	562
			Diameter	mm	5
	Motor system	Fan motor	Model		D-310-13-8N
	Dimension	Net Dimension(W*D*H)			mm
Packing Dimension(W*D*H)			mm	825×367×277	
Connection	Connect pipe		Liquid tube Diameter		6
			Gas tube Diameter		9
Outdoor unit configuration	Compressor Model				KSN98D27UER31
	Compressor Parameter	Brand			GMCC
	Motor system	Fan motor	Model		D-35-10L
	Condenser	Tube	Length	mm	702
			Diameter	mm	7
	Dimension	Net Dimension (W*D*H)			mm
Packing Dimension (W*D*H)			mm	825×595×345	
Container Loading 40HQ			Set		293

Product Model			AZI-WK35XA/I + AZI-WK35XA/O		
Nameplate Parameter	Rated Capacity	Cooling	W	3500	
		Heating	W	3800	
		Dehumidifying	Kg/h	1	
	Rated Power Consumption	Cooling	W	1180	
		Heating	W	1100	
	Rated Running Current	Cooling	A	5.6(0.7-7.8)	
		Heating	A	4.9(1.5-8.0)	
	Electric heating power		W	/	
	Max. Input Power		W	1900	
	Max. Input Current		A	9.5	
	EER Cooling		W/W	6.1	
	COP Heating		W/W	4	
	Power supply source		V/Ph/Hz	220-240V-1-50Hz	
	Refrigerant			R32	
	Refrigerant Charged		g	560	
	Max. Discharge Pressure		Mpa	4.3	
	Max. Suction Pressure		Mpa	2.5	
	Air Flow Volume		m3/h	600	
	Noise level		dB (A)	56	
	Noise level		dB (A)	62	
Indoor unit weight (Net)		Kg	7.5		
Outdoor unit weight (Net)		Kg	22.5		
Indoor unit configuration	evaporator	Tube	Length	mm	562
			Diameter	mm	5
	Motor system	Fan motor	Model		YYK18-4B
	Dimension	Net Dimension(W*D*H)		mm	761×296×199
Packing Dimension(W*D*H)		mm	825×367×277		
Connection	Connect pipe		Liquid tube Diameter		6
			Gas tube Diameter		9
Outdoor unit configuration	Compressor Model				KSN98D34UER3
	Compressor Parameter	Brand			GMCC
	Motor system	Fan motor	Model		D-35-10A
	Condenser	Tube	Length	mm	702
			Diameter	mm	7
	Dimension	Net Dimension (W*D*H)		mm	705×530×280
Packing Dimension (W*D*H)		mm	825×595×345		
Container Loading 40HQ			Set		293

Product Model				AZI-WK50XA/I + AZI-WK50XA/O	
Nameplate Parameter	Rated Capacity	Cooling		W	5300
		Heating		W	5400
		Dehumidifying		Kg/h	1.86
	Rated Power Consumption	Cooling		W	1650
		Heating		W	1470
	Rated Running Current	Cooling		A	7.8(2.2-9.3)
		Heating		A	6.5(2.0-8.0)
	Electric heating power			W	39
	Max. Input Power			W	2500
	Max. Input Current			A	12
	EER Cooling			W/W	6.8
	COP Heating			W/W	4.0
	Power supply source			V/Ph/Hz	220-240V~/50Hz
	Refrigerant				R32
	Refrigerant Charged			g	850
	Max. Discharge Pressure			Mpa	4.3
	Max. Suction Pressure			Mpa	2.5
	Air Flow Volume			m ³ /h	950
	Noise level			dB (A)	58
	Noise level			dB (A)	62
Indoor unit weight (Net)			Kg	11.5	
Outdoor unit weight (Net)			Kg	27	
Indoor unit configuration	evaporator	Tube	Length	mm	722
			Diameter	mm	5
	Motor system	Fan motor	Model		D-310-30-10A
	Dimension	Net Dimension(W*D*H)		mm	960×315×221
Packing		Dimension(W*D*H)	mm	1020×375×305	
Connection	Connect pipe		Liquid tube Diameter		6
			Gas tube Diameter		12
Outdoor unit configuration	Compressor Model				C-1RZ140H3DDF
	Compressor Parameter	Brand			SANYO
	Motor system	Fan motor	Model		D-40-10L
	Condenser	Tube	Length	mm	787/769
			Diameter	mm	5
	Dimension	Net Dimension (W*D*H)		mm	785×555×300
Packing Dimension (W*D*H)		mm	903×615×382		
Container Loading 40HQ			Set		208

Product Model			AZI-WK70XA/I + AZI-WK70XA/O		
Nameplate Parameter	Rated Capacity	Cooling	W	7300	
		Heating	W	7300	
		Dehumidifying	Kg/h	2.5	
	Rated Power Consumption	Cooling	W	2200 (230-2760)	
		Heating	W	2200 (230-2530)	
	Rated Running Current	Cooling	A	10 (1-12)	
		Heating	A	9.5 (1-11)	
	Electric heating power		W	39	
	Max. Input Power		W	3400	
	Max. Input Current		A	16	
	EER Cooling		W/W	6.5	
	COP Heating		W/W	4.0	
	Power supply source		V/Ph/Hz	220-240/50	
	Refrigerant			R32	
	Refrigerant Charged		g	1300	
	Max. Discharge Pressure		Mpa	4.3	
	Max. Suction Pressure		Mpa	2.5	
	Air Flow Volume		m3/h	1300	
	Noise level		dB (A)	63	
	Noise level		dB (A)	66	
Indoor unit weight (Net)		Kg	12.5		
Outdoor unit weight (Net)		Kg	39		
Indoor unit configuration	evaporator	Tube	Length	mm	850
			Diameter	mm	7
	Motor system	Fan motor	Model		D-310-50-10A
	Dimension	Net Dimension(W*D*H)		mm	1089×328×227
Packing Dimension(W*D*H)		mm	1155×397×312		
Connection	Connect pipe		Liquid tube Diameter		6
			Gas tube Diameter		15.88
Outdoor unit configuration	Compressor Model				C-6RZ146H3DEF
	Compressor Parameter	Brand			SANYO
	Motor system	Fan motor	Model		D-65-10L
	Condenser	Tube	Length	mm	892
			Diameter	mm	9.52
	Dimension	Net Dimension (W*D*H)		mm	900×700×350
Packing Dimension (W*D*H)		mm	1015×762×425		
Container Loading 40HQ			Set		143

4. Refrigerant System Diagram

4-1 Cooling Only

2 Cooling Mode

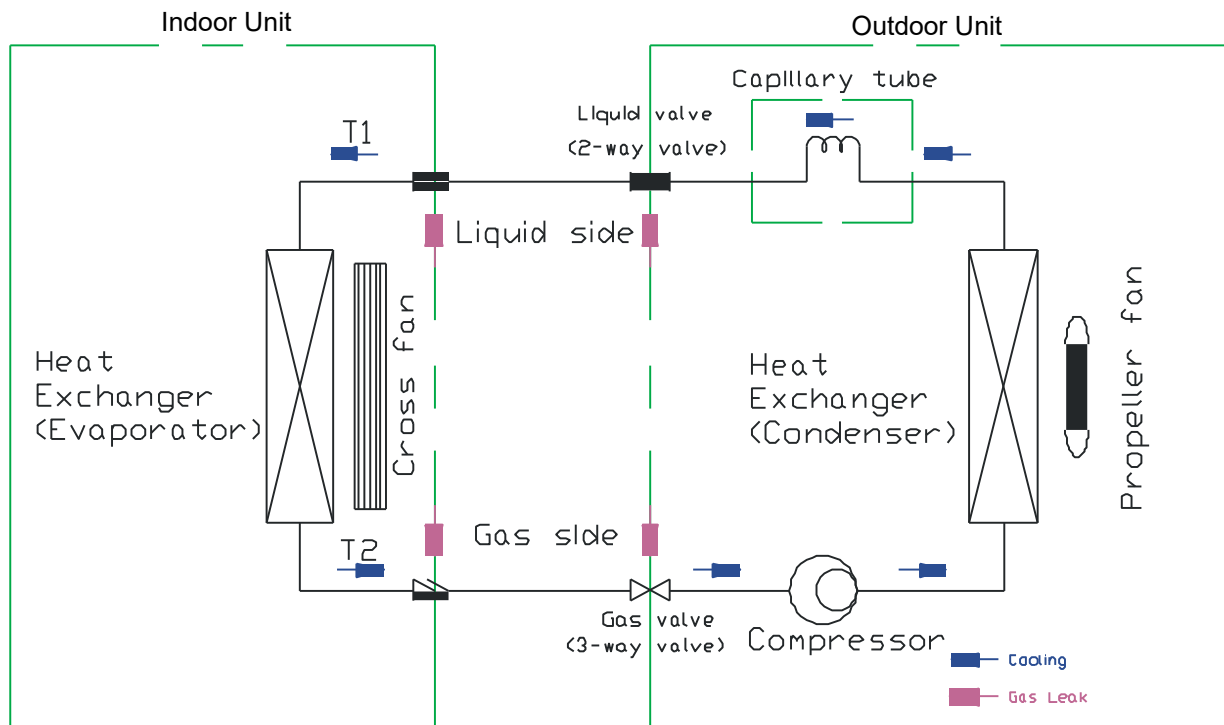

3 Cooling Cycle

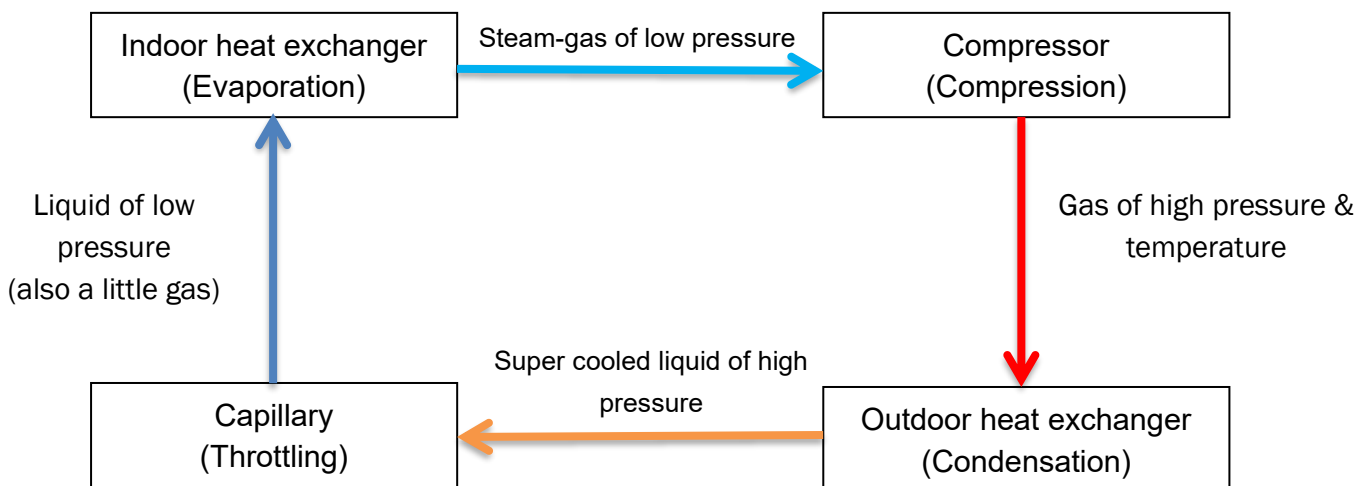

4-2 Cooling & Heating

4 Cooling Mode

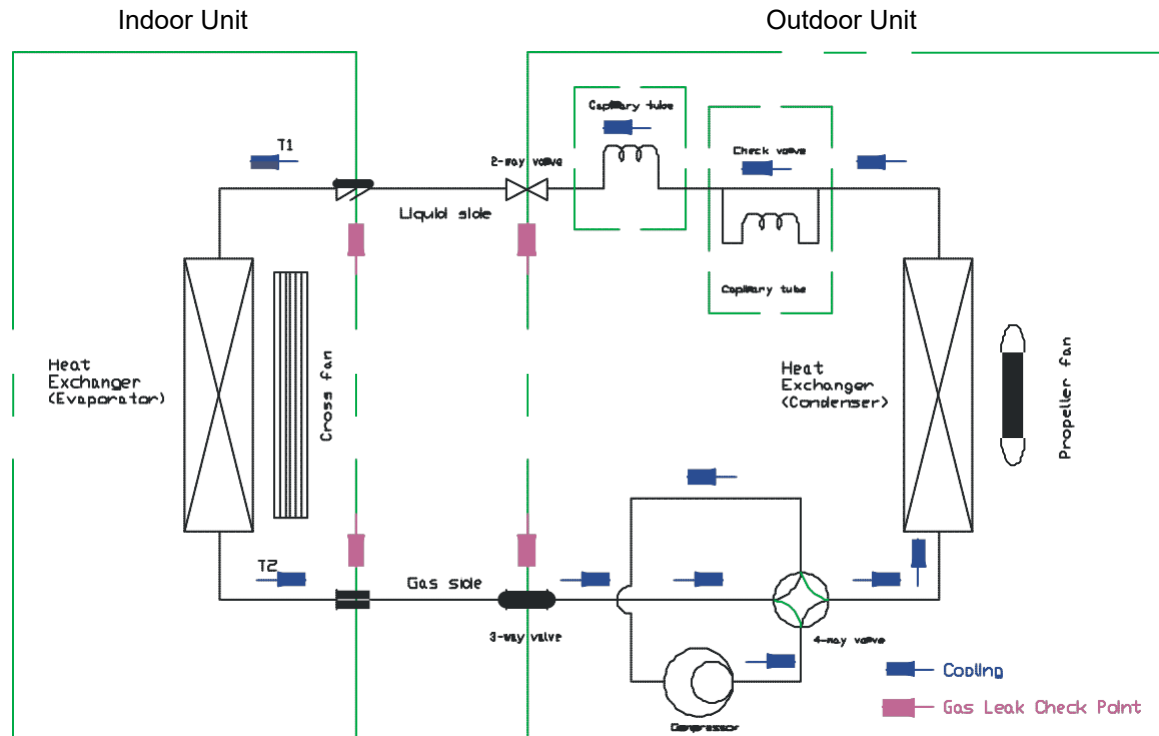

5 Cooling Cycle

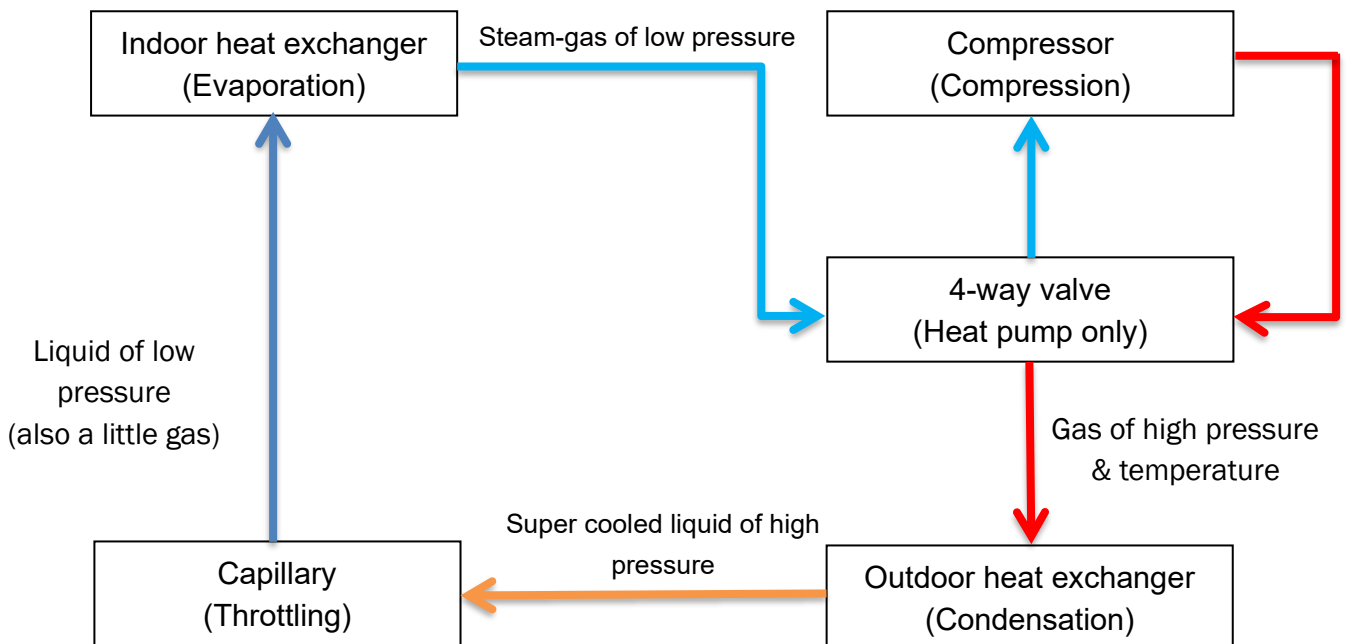

6 Heating Mode

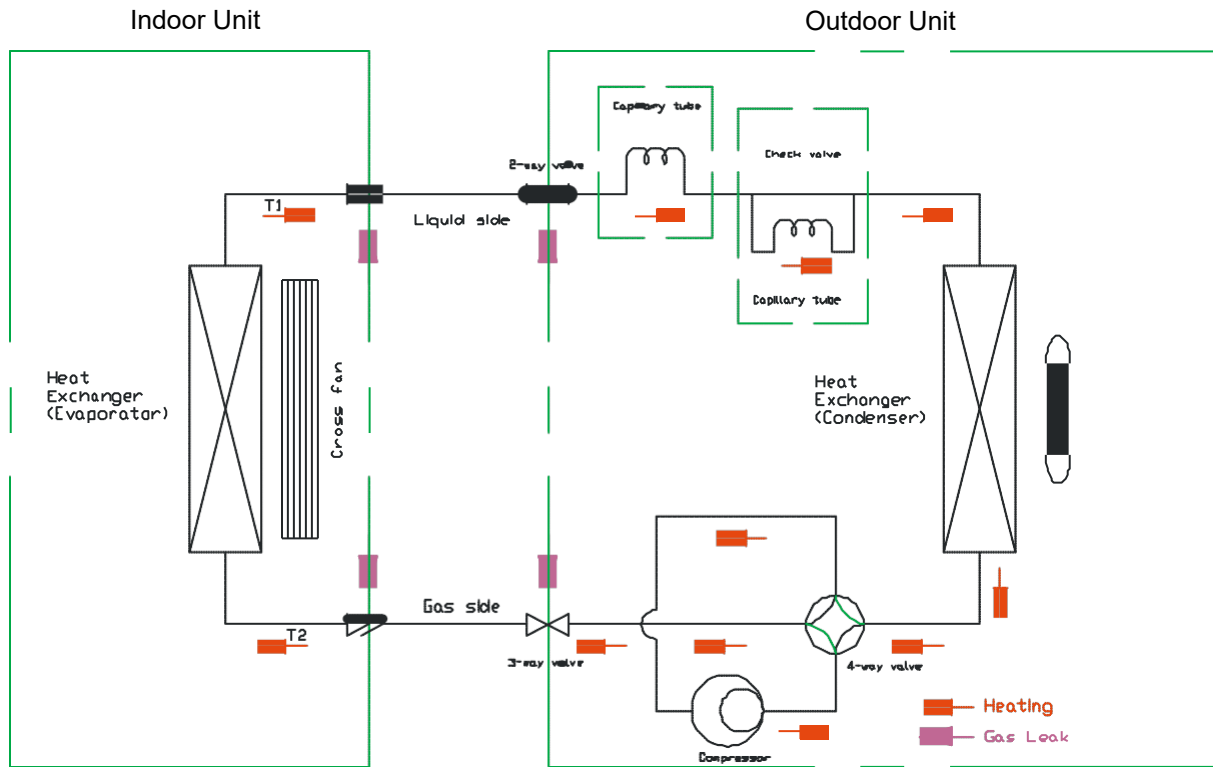

7 Heating Cycle

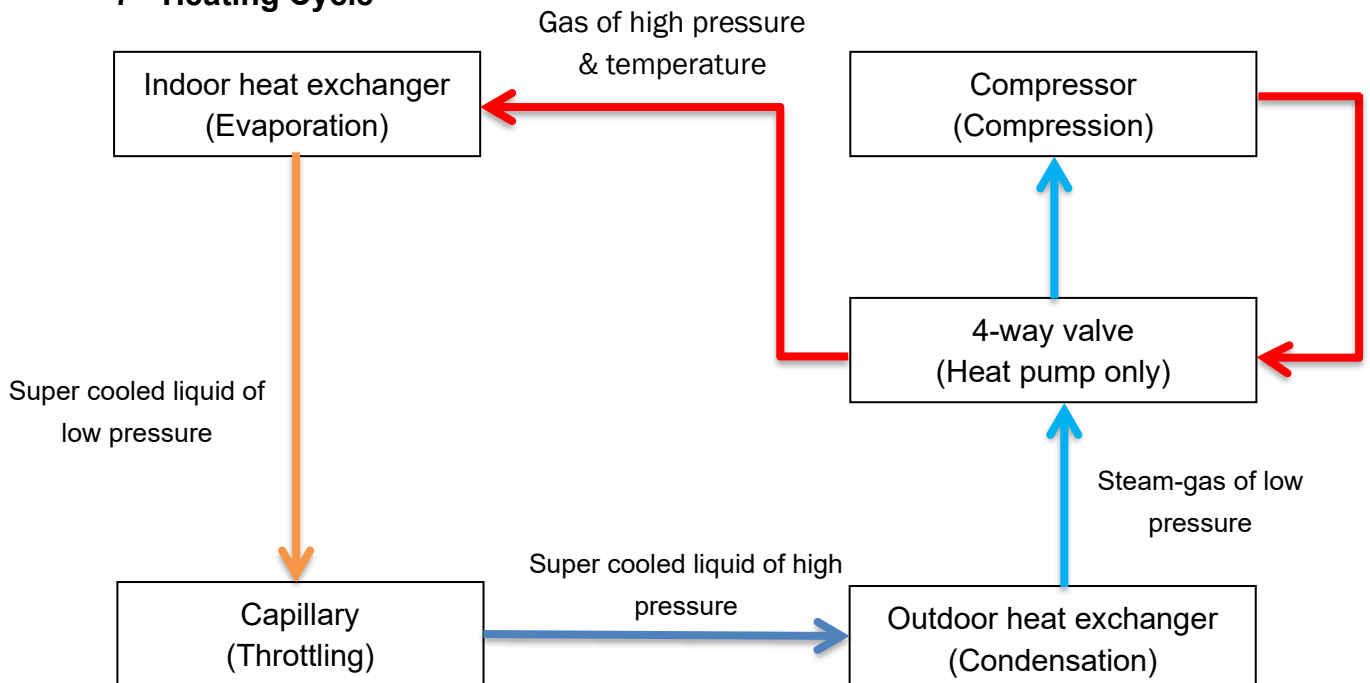

5. Electrical Part

5.1 Wiring Diagram

● Indoor Unit

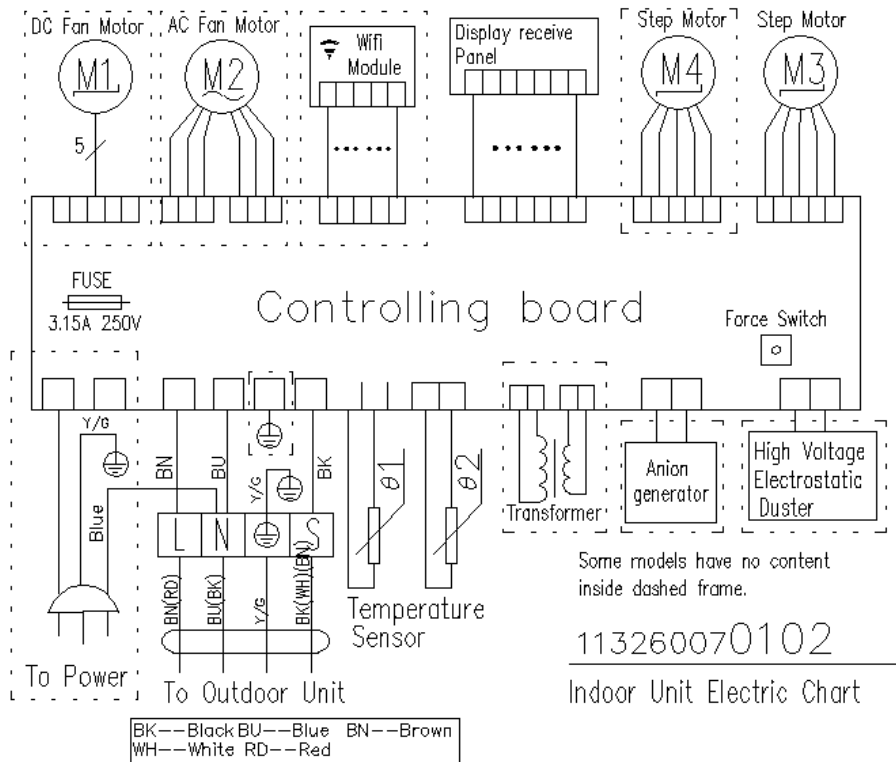

● Outdoor Unit

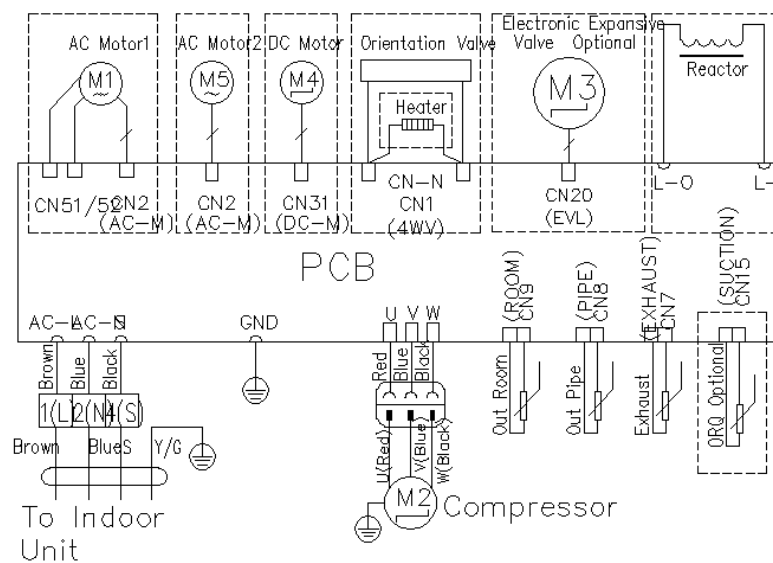

Part II : Installation and Maintenance

6. Main Tools for Installation and Maintenance

Screwdriver , Wire stripper	Tapeline , Spirit level	Allen wrench , Wrench
		
Hammer , Electric hammer	Water drill punch , Drill	Forming Drill
		
Cutting Knife	Belling Expander	Thermometer , Electro Probe
		
Pressure Gage	Pliers , Clip-on Ammeter	Vacuum Pump
		
Soldering Set	Refrigerant	Safety Belt , Safety Rope
		

7. Installation

7-1 Notes for Installation

Important Notices

- Before installation, please contact with local authorized maintenance center, if unit is not installed by the authorized maintenance center, the malfunction may not solved, due to discommodious contact.
- The air conditioner must be installed by professionals according to the national wiring rules and this manual.
- To move and install air conditioner to another place, please contact our local special service center.

Requirements For Installation Position

- Avoid places of inflammable or explosive gas leakage or where there are strongly aggressive gases.
- Avoid places subject to strong artificial electric/magnetic fields.
- Avoid places subject to noise and resonance.
- Avoid severe natural conditions (e.g. heavy lampblack, strong sandy wind, direct sunshine or high temperature heat sources).
- Avoid places within the reach of children.
- Shorten the connection between the indoor and outdoor units.
- Select where it is easy to perform service and repair and where the ventilation good.
- The outdoor unit shall not be installed in any way that could occupy an aisle, stairway, exit, fire escape, catwalk or any other public area.
- The outdoor unit shall be installed as far as possible from the doors and windows of the neighbors as well as the green plants.

Requirements for operations at raised height

- When carrying out installation at 2m or higher above the base level, safety belts must be worn and ropes of sufficient strength be securely fasten to the outdoor unit, to prevent falling that could cause personal injury or death as well as property loss.

Requirements of the mounting structure

- The mounting rack must meet the relevant national or industrial standards in terms of strength with welding and connection areas rustproofed.
- The mounting rack and its load carry surface shall be able to withstand 4 times or above the weight of the unit, or 200kg, whichever is heavier.
- The mounting rack of the outdoor unit shall be fastened with expansion bolt.
- Ensure the secure installation regardless of what type of wall on which it is installed, to prevent potential dropping that could hurt people.

Electrical Safety Requirements

- Be sure to use the rated voltage and air conditioners dedicated circuit for the power supply, and the power cord diameter must meet the national requirements.
- Be sure to use the rated voltage and air conditioners dedicated
- When the maximum current of air conditioner is $\geq 16A$, it must use the air switch or leakage protection switch equipped with protection devices.
- The normal operating range is 90%-110% of the local rated voltage.

- The minimum clearance between the air conditioner and the combustibles is 1.5 m.
- The power cable enables communication between the indoor and outdoor units. You must first choose the right cable size before preparing it for connection.

Grounding Requirements

- The air conditioner is the type I electrical appliance and must ensure a reliable grounding.
- Do not connect the grounding wire to a gas pipe, water pipe, lightning rod, telephone line, or a circuit poorly grounded to the earth.
- The grounding wire is specially designed and shall not be used for other purpose, nor shall it be fastened with a common tapping screw.

Others

- The connection method of the air conditioner and the power cord and the interconnection method of each independent element shall be subject to the wiring diagram affixed to the machine.
- The model and rating value of the fuse shall be subject to the silkscreen on corresponding controller or fuse sleeve.

7-2 Installation of Indoor Unit

8 Installation Parts-checking

Packing list of the indoor unit

NO.	Name	Quantity	Unit
1	Indoor Unit	1	Set
2	Remote Controller	1	PC
3	Batteries(7#)	2	PC
4	Instructions	1	Set
5	Drain pipe	1	PC

NOTE:

※ All accessories shall be subject to actual packaging material, and if there is any difference, please understand.

9 Selection of Installation location

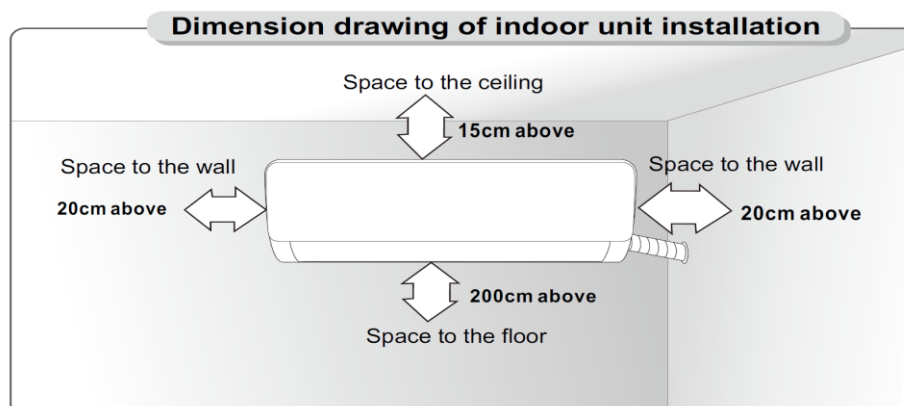

10 Mounting plate

1. The wall for installation of the indoor unit shall be hard and firm, so as to prevent vibration.
2. Use the "+" type screw to fasten the peg board, horizontally mount the peg board on the wall, and ensure the lateral horizontal and longitudinal vertical.
3. Pull the peg board by hand after the installation, to confirm whether it is solid.

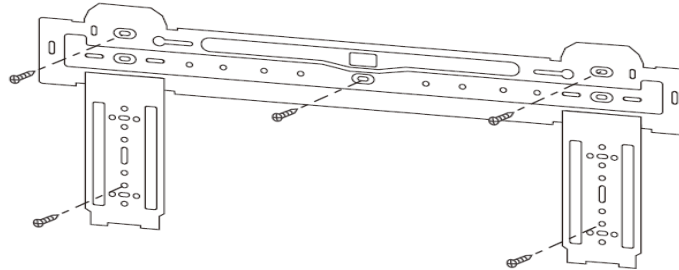

11 Wall-through Hole

1. Make a hole with an electric hammer or a water drill at the predetermined position on the wall for piping, which shall slant outwardly by 5°-10°.
2. To protect the piping and the cables from being damaged running through the wall, and from the rodents that may inhabit in the hollow wall, a pipe protecting ring shall be installed and sealed with putty.

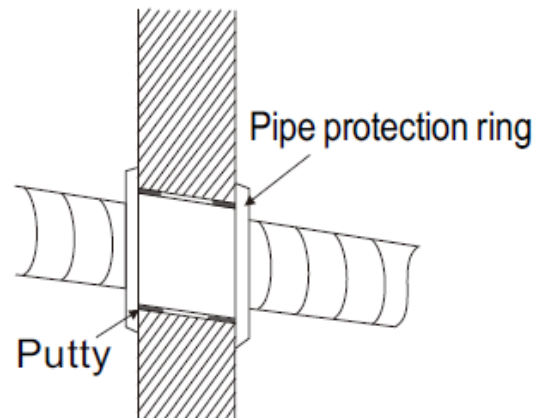

Note: Usually, the wall hole is $\Phi 60\text{mm}$ ~ $\Phi 80\text{mm}$. Avoid pre-buried power wire and hard wall when making the hole.

12 Route of Pipeline

1. Depending on the position of the unit, the piping may be routed sideway from the left or the right (Fig 1), or vertically from the back(Fig 2)(depending on the pipe length of the indoor unit). In the case of sideway routing, cut off the outlet cutting stock of the opposite side.
2. The power cord may be routed separately from the piping. Cut off the outlet cutting stock and then run the power cord through the hole, keeping the remaining part as a protection from rodents.

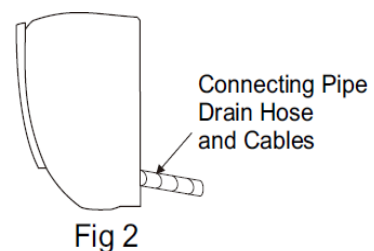
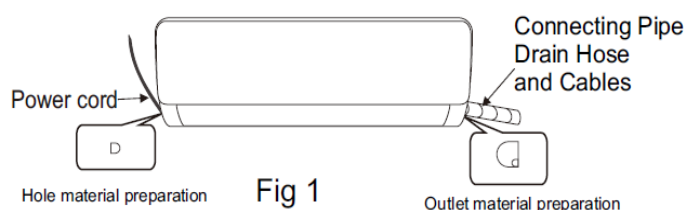

13 Drain pipe connection

1. Remove the mountings and pull the indoor unit pipe out of the housing.
2. Connect the connecting pipe to the indoor unit:

Aim at the pipe center, tighten the Taper nut with fingers, and then tighten the T nut with a torque wrench, and the direction is shown in diagram on the right. The torque used is shown in the following table.

Tightening torque table

The size of pipe(mm)	Torque(N·m)
Φ6/Φ6.35	15 ~ 25
Φ9 /Φ9.5 2	35 ~ 40
Φ12/Φ12.7	45 ~ 60
Φ15.88	73 ~ 78
Φ19.05	75 ~ 80

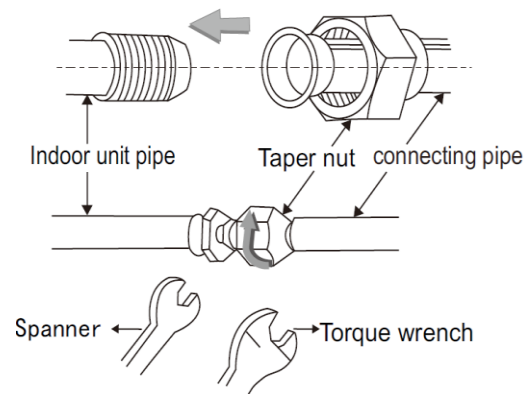

14 Wrap the Piping

1. Use the insulation sleeve to wrap the joint part the indoor unit and the connection pipe, and then use insulating material to pack and seal insulation pipe, to prevent generation of condensate water on the joint part.
2. Connect the water outlet with drain pipes, and make the connection pipe, cables, and the drain hose straight.
3. Use plastic cable ties to wrap the connecting pipes, cables and drain hose. Run the pipe sloping downward.

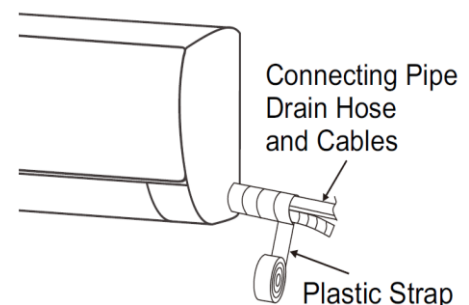

16 Fixing the indoor unit

1. Hang the indoor unit on the peg board, and move the unit from left to right to ensure that the hook is properly positioned in the peg board.
2. Push toward the lower left side and the upper right side of the unit toward the peg board, until the hook is embedded in the slot and makes a "click" sound.

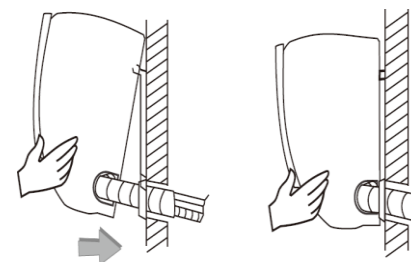

17 Electric Connection Requirement

- Loosen the screws and remove from the unit.
- Connect the cables respectively to the corresponding terminals of the terminal board of the indoor unit (see the wiring diagram), and if there are signals connected to the plug, just conduct butt joint.

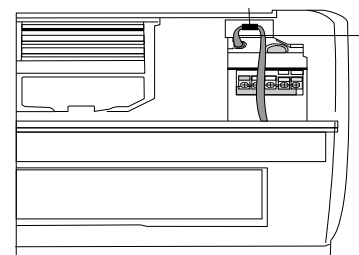

- Ground wire: Remove the grounding screw out of the electric bracket, cover the grounding wire end onto the grounding screw and screw it into the grounding hole.
- Fix the cable reliably with fasteners (Pressing board).
- Put the E-parts cover back in its original place and fasten it with screws.

7-3 Installation of outdoor Unit

18 Packing list of the outdoor unit

NO.	Name	Quantity	Unit
1	Outdoor Unit	1	Set
2	Connecting pipe	2	PC
3	Plastic Strap	1	ROLL
4	Pipe Protection Ring	1	Set
5	Luting (putty)	1	PACKET

19 Selection of Installation location

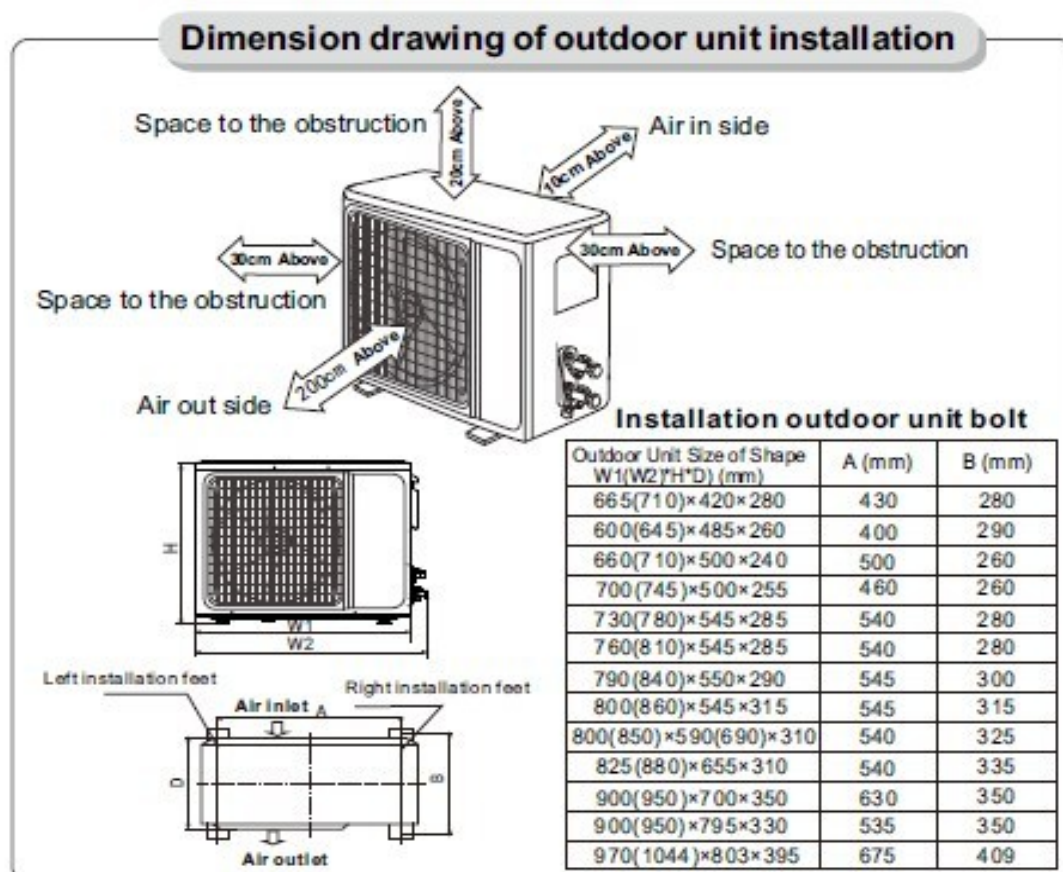

20 Install the connection pipe

Connect the Outdoor Unit with Connecting Pipe: Aim the counter-bore of the connecting pipe at the stop valve, and tighten the Taper nut with fingers. Then tighten the Taper nut with a torque wrench.

★When prolonging the piping, extra amount of refrigerant must be added so that the operation and performance of the air conditioner will not be compromised.

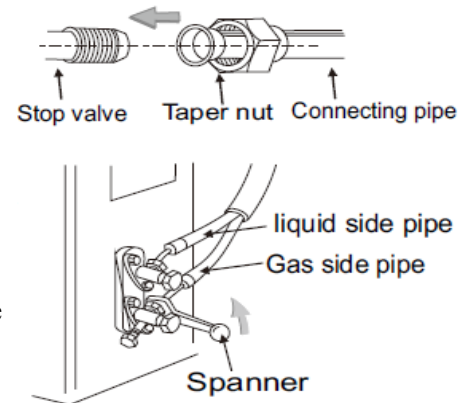

Piping length	Amount of refrigerant to be added	
≤5M	Not needed	
5- 15M	CC≤12000Btu	20g/m
	CC≥18000Btu	30g/m

Note: This table is for reference only.

21 Wiring Connection

- Loosen the screws and remove E-parts cover from the unit.
- Connect the cables respectively to the corresponding terminals of the terminal board of the outdoor unit (see the wiring diagram), and if there are signals connected to the plug, just conduct butt joint.
- Ground wire: Remove the grounding screw out of the electric bracket, cover the grounding wire end onto the grounding screw and screw it into the grounding hole.
- Fix the cable reliably with fasteners (Pressing board).
- Put the E-parts cover back in its original place and fasten it with screws.

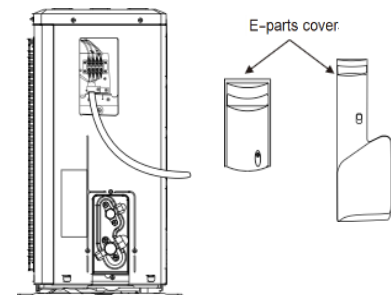

22 Expelling the air

★Outdoor unit refrigerant discharging method

After the pipe side connection is complete, proceed as follows.

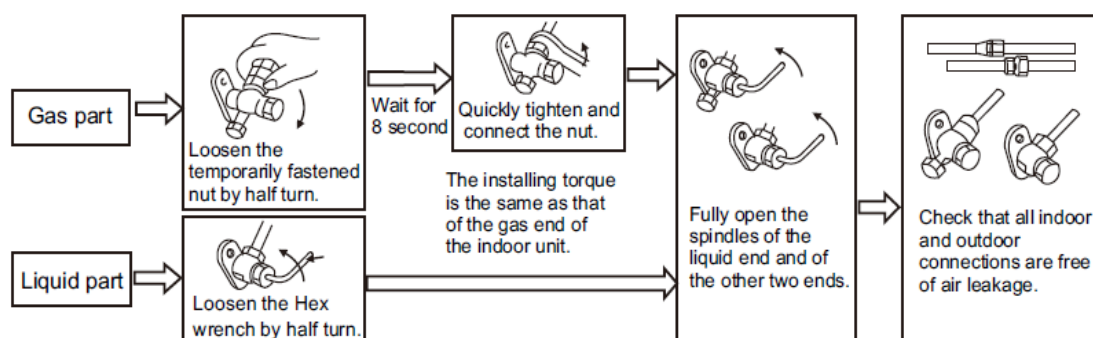

★Vacuum Pumping Method (R410A refrigerant evacuation must use the vacuum pumping method)

Before working on the air conditioner, remove the cover of the stop valve(gas and liquid valves)and be sure to retighten it afterward.(to prevent the potential air leakage)

1. To prevent air leakage and spilling tighten all connecting nut of all flare tubes.
2. Connect the stop valve, charge hose, manifold valve, and vacuum pump.
3. Fully open the handle Lo of the manifold valve and apply vacuum for at least 15 minutes and check that the compound vacuum gauge reads -0.1MPa (-76cmHg).

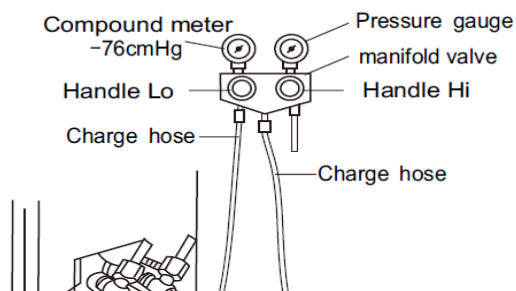

When the unit is heating, the condensing water and defrosting water can be out reliably through the drain house.

Installation :

Install the outdoor drain elbow in $\Phi 25$ hole on the base plate, and joint the drain hose to the elbow, so that the waste water formed in the outdoor unit can be drained out to a proper plate.

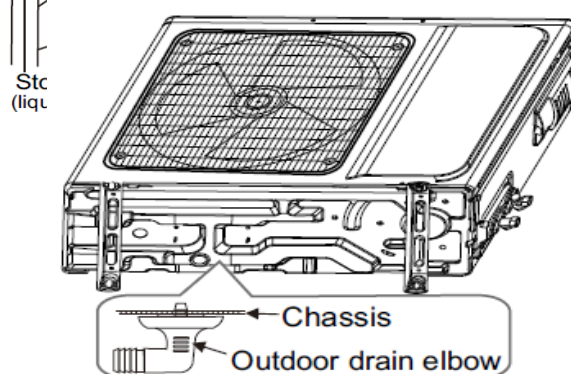

7-4 Check after installation and test operation

1. Check after installation

★ Electrical Safety Check

- ① If the supply voltage is as required.
- ② If there is any faulty or miss connection in each of the power, signal and grounding wires.
- ③ If the grounding wire of the air conditioner is securely grounded.

★ Installation Safety Check

- ① If the installation is secure.
- ② If the water drain is smooth.
- ③ If the wiring and piping are correctly installed.
- ④ Check that no foreign matter or tools are left inside the unit.

★ Leak test of the refrigerant

Depending on the installation method, the following methods may be used to check for suspect leak, on areas such as the four connections of the outdoor unit and the cores of the cut-off valves and t-valves:

- ① Bubble method: Apply of spray a uniform layer of soap water over the suspected leak spot and observe carefully for bubble.
- ② Instrument method: Checking for leak by pointing the probe of the leak detector according to the instruction to the suspect points of leak.

2. Test operation

★ Test preparation

- ※Verify that all piping and connection cables are well connected.
- ※Confirm that the valves at the gas side the liquid-side are fully open.
- ※Connect the power cord to an independent power socket.
- ※Install batteries in remote control.

★ Test Operation method

- ① Turn on the power and push the ON/OFF switch button of the remote controller to start the air conditioner.
- ② Select COOL, HEAT (not available on cool-only models), SWING and other operation modes with the remote controller and see if the operation is ok.

8. Maintenance

8-1 Troubleshooting Guide

Many error codes many appears on this air conditioner, and this troubleshooting guide is prepared for the maintenance personnel to detect the error position and the parts to be replaced during the troubleshooting process. In this Guide, the Troubleshooting Method is guided by the Error Name, and the Reference Code under the General Index is the error code of the Indoor Unit of the mainstream model supplied by the Company.

Example: “Indoor Unit coil sensor error” is coded as E3 in the error code of the Indoor Unit, but appears as flash-out via the trouble light of the Outdoor Unit machine. However, their troubleshooting method is the same, and use the same table as well.

General index: fix speed air conditioners only involve E1, E2, E3 and E4

No.	Error Name	Error Code
1	Overcurrent Protection of Indoor Unit	E0
2	Indoor Unit temperature sensor error	E1
3	Outdoor Unit coil sensor error	E2
4	Indoor Unit coil sensor error	E3
5	Indoor Unit motor error of wall mounted air conditioner (PG motor)	E4
6	Indoor Unit motor error of wall mounted air conditioner (DC motor)	E4
7	Indoor Unit and Outdoor Unit communication error	E5(5E)
8	Indoor EE Failure	Eb
9	Outdoor Unit DC motor error (3-core terminal motor)	F0
10	Module protection error	F1
11	PFC protection error	F2
12	Compressor startup error	F3
13	Discharge sensor error	F4
14	Pressing top head sensor error	F5
15	Outdoor Unit temperature sensor error	F6
16	OVP or UVP error	F7
17	Outdoor Unit main PCB and module panel communication error	F8
18	Outdoor EE error	F9
19	Recirculated sensor error (four-way valve switch error)	FA
20	High-pressure protection	P2
21	Liquid Deficiency Protection	P3
22	Refrigeration Overload Protection	P4
23	Discharge Protection	P5
24	Indoor High Temperature Protection	P6

25	Anti-freezing Protection in Refrigeration Room	P7
26	Overcurrent Protection	P8
27	DC Over/Under-voltage Failure	L0
28	Overcurrent Protection on Phase Current of Compressor	L1
	Out-of Step Failure of Compressor	L2
29	Phase Failure of Compressor	L3
30	Driver Module IPM Failure of Compressor	L4
31	PFC Overcurrent Hardware Protection	L5
	PFC Overcurrent Software Protection	L6
	AD Abnormal Protection in Current Detection	L7
	AD Abnormal Protection in PFC Current Detection	LC
	Dc fan motor detection AD abnormal protection	Ld
32	Shunt Resistance Imbalance Failure	L8
33	IPM Temperature Sensor Failure	L9
34	Compressor Startup Failure	LA
35	DC fan motor phase error	LE
	DC fan motor lost step protection	LF
36	DC fan motor IPM protection	LH

Example:

Explanation of error	Cause: explain the principle of the specific error. Inspection path: The basic order of troubleshooting. Related key position
Tools required for inspection	Tools that should be carried for such troubleshooting, and replacing parts that may be necessary for such error.
Common faulty components	Any possibly broken part related to the error may be the parts that need to be replaced.
Inspection procedure and key points	All the troubleshooting procedures for the reference of maintenance staff are prepared from simple to complex, from surface to Indoor Unit, and from test to replacement. these key points do not cover all the error, and difficult or special problems are not included as well, but they can cover most of the common error.
Special attention	Here are some often-overlooked problems for the reference of the maintenance personnel.

The problems in the market are always more than we think, so it is necessary for the maintenance personnel to understand the principle of air conditioning operation, and to make a flexible judgment of the fault in combination with the actual conditions. We welcome the maintenance personnel to constantly put forward new problems in the actual work, record the solutions and enrich our troubleshooting guide list.

(1) E0- Overcurrent Protection of Indoor Unit

Explanation of error	<p>Cause: The main PCB detects that the working current of the system exceeds the upper limit of protection, and will indicate "indoor unit overcurrent protectin:. The air conditioner stops running for protection and displays the failure code E0.</p> <p>Inspection path: current transformer → power line → compressor line → connector assembly</p>
Tools required for inspection	<p>Current clamp and multimeter</p>
Common faulty components	<p>Indoor unit panel, power line, compressor and complete machine</p>
Inspection procedure and key points	<ol style="list-style-type: none"> 1. If it is a fixed-frequency model, observe whether the live line passes through the current transformer; if not, lay the line accordingly and reboot for inspection. 2. The current clamp is used to measure the working current and determine whether it is within the normal working current range of the nameplate. If normal working current is detected, it may be the fault of the current transformer and replace the main PCB of the indoor unit. 3. Measure whether the power supply voltage is within the normal operating voltage range; if the working voltage is not normal, it is necessary to consider whether the local grid voltage is stable. 4. If the working current exceeds the range and the working voltage is normal, the system may be blocked and the air-conditioning may be overloaded, which needs to be checked according to the actual situation.

(2) E1- Indoor Unit temperature sensor error

Explanation of error	<p>Cause: The detection of short circuit or open circuit of Indoor Unit temperature sensor during the inspection of main PCB in the Indoor Unit machine, indicated by "Indoor Unit temperature sensor error".</p> <p>Inspection path: Sensor→Sensor wire→Connectors→Indoor Unit main PCB</p>
Tools required for inspection	<p>Multimeter, 15KΩ standard sensor (25℃)</p>
Common faulty components	<p>Indoor Unit temperature sensor, Indoor Unit main PCB</p>

<p>Inspection procedure and key points</p>	<ol style="list-style-type: none"> 1. Check whether there's resistance problem, short circuit or open circuit in the sensor; the resistance value shall be within a reasonable range (15KΩ under the temperature of 25°C for frequency conversion machine) 2. Check whether the sensor wire is broken. 3. Check whether the terminal connectors are well fixed; check whether the weld between the terminal and the main PCB is loose, and pull the terminal slightly for inspection if necessary. 4. Check whether the sensor is affected with damp. 5. In case no standard sensor is available at present, replace the Indoor Unit temperature sensor by other sensor asides, and then check whether the error still exists; if the error disappears, replace the sensor; if the error still exists, check the Indoor Unit main PCB and change if necessary.
<p>Special attention</p>	<p>Most Indoor Unit temperature sensors of the frequency conversion machine have a resistance value of 15KΩ.</p> <p>Do not use improper sensor during repairing and maintenance, or it may led to the wrong temperature sensing of the machine, the start error or shutdown error. You can switch the air conditioner to the “Blowing” mode, and judge the accuracy of sensor though environmental temperature displayed on the screen.</p> <p>In case a sensor with the resistance value over 15KΩ is used, the detected temperature will be much lower than the actual temperature, which may lead to the shutdown error under heating mode, or the startup error under cooling mode.</p> <p>In case a sensor with the resistance value below 15KΩ is used, the detected temperature will be much higher than the actual temperature, which may lead to the startup error under heating mode, or the shutdown error under cooling mode.</p>

(3) E2 -Outdoor Unit coil sensor error

<p>Explanation of error</p>	<p>Cause: The detection of short circuit or open circuit of Outdoor Unit coil sensor during the inspection of Outdoor Unit main PCB, indicated by “Outdoor Unit coil sensor error”.</p> <p>Inspection path: Sensor→Sensor wire→Connectors→Outdoor Unit main PCB</p>
<p>Tools required for inspection</p>	<p>Multimeter, 20KΩ standard sensor (25°C)</p>
<p>Common faulty components</p>	<p>Outdoor Unit coil sensor, Outdoor Unit main PCB</p>

<p>Inspection procedure and key points</p>	<ol style="list-style-type: none"> 1. Check whether there's resistance problem, short circuit or open circuit in the sensor; the resistance value shall with a reasonable range (about 20KΩ for frequency conversion machine) 2. Check whether the sensor wire is broken. 3. Check whether the terminal connectors are well fixed; check whether the weld between the terminal and the main PCB is loose, and pull the terminal slightly for inspection if necessary. 4. Check whether the sensor is affected with damp. The coil sensor is quite easy to be affected with damp in case the lead of coil sensor is above the copper pipe. 5. In case no standard sensor is available at present, replace the temperature sensor of Outdoor Unit coil by other sensor asides, and then check whether the error still exists; if the error disappears, replace the sensor; if the error still exists, check the Indoor Unit main PCB and change if necessary.
<p>Special attention</p>	<p>Most Indoor Unit temperature sensors of the frequency conversion machine have a resistance value of 20KΩ.</p> <p>Do not use improper sensor during repairing and maintenance, or it may led to the start of protection mode due to wrong temperature sensing of the machine, or the protection error.</p> <p>In case a sensor with the resistance value over 20KΩ is used, the detected temperature will be much lower than the actual temperature, which may lead to the frequent entering of defrost mode, the illusory defrosting or the protection error during the cooling process.</p> <p>In case a sensor with the resistance value below 20KΩ is used, the detected temperature will be much higher than the actual temperature, which may lead to defrost error during the heating process, or the start of protection during the cooling process.</p>

(4) E3 -Indoor Unit coil sensor error

<p>Explanation of error</p>	<p>Cause: The detection of short circuit or open circuit of Indoor Unit coil sensor during the inspection of Indoor Unit main PCB, indicated by “Indoor Unit coil sensor error”.</p> <p>Inspection path: Sensor→Sensor wire→Connectors→Indoor Unit main PCB</p>
<p>Tools required for inspection</p>	<p>Multimeter,, 5KΩ or 20KΩ standard sensoe (25℃)</p>
<p>Common faulty components</p>	<p>Indoor Unit temperature sensor, Indoor Unit main PCB</p>

<p>Inspection procedure and key points</p>	<ol style="list-style-type: none"> 1. Check whether there's resistance problem, short circuit or open circuit in the sensor; the resistance value shall with a reasonable range (about 20KΩ for frequency conversion machine) 2. Check whether the sensor wire is broken. 3. Check whether the terminal connectors are well fixed; check whether the weld between the terminal and the main PCB is loose., and pull the terminal slightly for inspection if necessary. 4. Check whether the sensor is affected with damp. The coil sensor is quite easy to be affected with damp in case the lead of coil sensor is above the copper pipe. 5. In case no standard sensor is available at present, replace the temperature sensor of Indoor Unit coil by other sensor asides, and then check whether the error still exists; if the error disappears, replace the sensor; if the error still exists, check the Indoor Unit main PCB and change if necessary.
<p>Special attention</p>	<p>Most Indoor Unit temperature sensors of the frequency conversion machine have a resistance value of 20KΩ.</p> <p>Do not use improper sensor during repairing and maintenance, or it may led to the start of anti-frosting or overheat protection mode due to wrong temperature sensing of the machine.</p> <p>In case a sensor with the resistance value over 20KΩ is used, the detected temperature will be much lower than the actual temperature, which may lead to the high pressure of cold-blast protection system during the heating process, or the frequent start of anti-freezing protection during the cooling process.</p> <p>n case a sensor with the resistance value below 20KΩ is used, the detected temperature will be much higher than the actual temperature, which may lead to the frequent start of overheat protection mode during the heating or the overload protection during the cooling process.</p>

(5) E4 -Indoor Unit motor error of wall mounted air conditioner (PG motor)

<p>Explanation of error</p>	<p>Cause: PG motor is equipped with speed feedback signal line. When the feedback signal of speed is not received by the Indoor Unit main PCB, it has no way to recognize the rotating speed of motor, which will be indicated as “Indoor Unit motor error”. Main causes for the disappearance of speed feedback signal are as follows: 1. The speed feedback component in the motor is broken; 2. The speed feedback component in the motor is broken; 3. Error of receiving circuit for the speed feedback signal from the Indoor Unit main PCB.</p>
<p>Tools required for inspection</p>	<p>Multimeter, A PG motor in normal working condition</p>

Common faulty components	Mechanical jam problem of Indoor Unit motor, PG motor, Indoor Unit main PCB
Inspection procedure and key points	<ol style="list-style-type: none"> 1. Check whether the motor can work for a period of time before the error occurs. If yes, the reason of mechanical jam can be exclude. 2. Disconnect the power supply and move the fan blade of Indoor Unit machine by hand to see if there's any resistance. Some occasional Indoor Unit motor error may relate to bearing coordination. 3. Reconnect the drive wire and speed feedback wire, thus to exclude any motor error due to connector loosening. 4. Check whether the plug-in terminal of speed feedback on the PCB is loose, and pull the terminal slightly for inspection if necessary. 5. Replace the motor in the faulted air conditioner with other PG motor (do not fix it with the fan for the time being), if the main PCB still indicates "Indoor Unit motor error", then replace the Indoor Unit main PCB; if the error disappears, replace the Indoor Unit motor.
Special attention	<p>The Indoor Unit main PCB will not indicates "Indoor Unit motor error" when the Indoor Unit motor is still rotating; sometimes such error will not be reported when obvious motor problems exist (such as the low-speed rotation due to damaged motor capacitors, or non-uniform rotating speed due to abnormal speed feedback.</p> <p>Therefore, patience of the maintenance staff is required for the troubleshooting of motor error. You shall compare it with the normal condition, and detect and solve the problem in a flexible way.</p>

(6) E4- Indoor Unit motor error of wall mounted air conditioner (DC motor)

Explanation of error	<p>Cause: The Indoor Unit motor of some highly energy efficient models is DC motor using a green plug through which the Indoor Unit main PCB can drive the motor and sense the current rotational speed feedback. When the Indoor Unit main PCB cannot receive the rotational speed feedback signal of the motor, it will indicate "DC motor error". Disappearance of the rotational speed feedback signal may be caused by:</p> <ol style="list-style-type: none"> 1 The fan is stuck and cannot work; 2 The speed feedback element inside the motor is destroyed; 3 There's something wrong with the speed feedback signal receiving circuit of the Indoor Unit main PCB. <p>Inspection path: Is DC motor stuck by foreign matter→motor destroyed → Motor terminal connectors→Indoor Unit main PCB</p>
Tools required for inspection	Multimeter, a DC motor in normal working condition
Common faulty components	Mechanical jam of Indoor Unit motor, Indoor Unit DC motor, Indoor Unit main PCB

<p style="text-align: center;">Inspection procedure and key points</p>	<ol style="list-style-type: none"> 1. Check whether the motor accelerates to extremely high speed before the error occurs. If it can work for a period, the reason of mechanical jam can be excluded. 2. Plug and unplug the terminal of the DC motor again to exclude any motor error due to connector loosening, and pull the terminal slightly for inspection if necessary. 3. Replace the motor in the faulted air conditioner with other DC motor to plug in the Indoor Unit main PCB (do not fix it with the fan for the time being), if the main PCB still indicates “DC motor error”, then replace the Indoor Unit main PCB; if the error disappears, replace the DC motor. 4. Multimeter can be used to distinguish whether it is main PCB problem or motor problem by: connect the motor with the main PCB and pay attention to the second (yellow) and fourth (black) wire from the outermost side among four lines of the terminal of the DC motor. After the air conditioner powers on in the cooling mode for a while, the voltage between the yellow and black wires should rise gradually and the motor should accelerates slowly, if the DC motor still won't rotate, then the DC motor is destroyed.
<p style="text-align: center;">Special attention</p>	<p>Five lead wires division: Count from the outermost side of the four wires of the DC motor terminal, the first blue wire is the speed feedback wire with a voltage of 0.5-5V when the motor rotates; the second yellow wire is the motor driving wire with a voltage of 2.0-7.5V when the motor rotates; the second white wire is 15V power cord with a voltage of 15V in normal condition; the fourth black wire is 0V DC earth wire which is the benchmark of all the voltage tests; the fifth (red) wire is 310V wire which is strong with a voltage of 310V in normal condition, so be careful of electric shock.</p>

(7) E5(5E) -Indoor Unit and Outdoor Unit communication error

<p>Explanation of error</p>	<p>Cause: The frequency converter needs Indoor Unit and Outdoor Unit communication. When the communication cannot be reached, the Indoor Unit and Outdoor Units will indicate “Indoor Unit and Outdoor Unit communication error”. Only “Indoor Unit main PCB, connecting cable and Outdoor Unit main PCB” are related to communication; but sometimes the communication error will be indicated when the Outdoor Unit has no power and the Indoor Unit cannot connect with the Outdoor Unit due to other errors, then such situation shall be distinguished from “pure communication error” and treated in a different way.</p> <p>Inspection path: Check if the Outdoor Unit can power on and work (normally, the indicator light will turn off after lighting for several seconds, relay picks up, and PTC won’t heat seriously)</p> <p>1. Can power on and work: Are the Indoor Unit and Outdoor Unit matched→is the phase sequence of connecting wires of Indoor Unit and Outdoor Units correct (the live wire of the Indoor Unit connects with that of the Outdoor Unit, the null wire of the Indoor Unit connects with that of the Outdoor Unit)→Connecting wires touched well→Indoor Unit main PCB replacement→Outdoor Unit main PCB replacement</p> <p>2. Cannot power on and work: Can AC 220V be delivered to the terminal block of the Outdoor Unit→Can the bridge rectifier and module panel generate DC 310V→Can the Outdoor Unit main PCB generate a low voltage power supply of DC 5V→Does the Outdoor Unit main PCB show the status of periodical reset.</p>
<p>Tools required for inspection</p>	<p>Multimeter, Indoor Unit main PCB in normal condition</p>
<p>Common faulty components</p>	<p>Connecting wire phase sequence and contact, Indoor Unit main PCB, Outdoor Unit main PCB, module panel</p>
<p>Inspection procedure and key points</p>	<p>1. Firstly, the IDU and the ODU should be matched and connected properly.</p> <p>2. Observe the Outdoor Unit main PCB, turn on the air conditioner, three lights are all lighted up then off and the relay pulls in. If not, it is power supply problem.</p> <p>3. Connect the black signal line S to terminal N of ODU. Turn on the A/C, if "E5" is still reported, the Outdoor Unit main PCB need to be replaced. If "E5" is still reported at this time, go to step 4.</p> <p>4. Change a new Indoor Unit main PCB, if the error code E5 remains, then the problem should be on the Outdoor Unit main PCB.</p>

Special attention	<p>When the Outdoor Unit not power on: If the Indoor Unit terminal board does not transmit 220V power, replace the Indoor Unit main PCB; if the Outdoor Unit terminal board has 220V power, first check if (fuse, reactor and bridge rectifier) are normal. There is still something wrong, replace the whole set of Outdoor Unit control unit; for the control unit composed of several function boards, try disconnecting the weak-current data wires among several control boards and then power the Outdoor Unit on, if the main PCB can be powered on and initialized successfully, then it's the module panel problems; if the Outdoor Unit main PCB still cannot be powered on and initialized, replace the Outdoor Unit main PCB.</p>
--------------------------	--

(8) Eb –Indoor EE Failure

Explanation of error	<p>Cause: Many parameters need to be preset for the running of the indoor unit of the air conditioner and such parameters are placed in a data storage 8-foot chip, which is called "EEPROM" or "EE" for short. The motor on the Indoor Unit main PCB can only work after reading the data stored in EE and if not read, the failure code "Outdoor EE Failure" will be indicated and raised in the indoor unit. Reasons for data not being read are as follows:</p> <ol style="list-style-type: none"> 1. wrong EE chip data format; 2. EE chip is broken; 3. bad contact of EE or fault of EE reading circuit; 4. backward installation of EE chip. <p>Inspection path: Indoor Unit main PCB.</p>
Tools required for inspection	/
Common faulty components	Bad contact of EE, Indoor Unit main PCB.
Inspection procedure and key points	Replace the Indoor Unit main PCB directly.

(9) F0- Outdoor Unit DC motor error (3-core terminal motor)

Explanation of error	<p>Cause: Our frequency changing Outdoor Unit uses the 3-lead-wire DC motor, or “Outdoor Unit driven DC motor” for short, after 2012. It has no speed feedback circuit but 3 drive lead wires and its driving principle is similar to that of the compressor. The main PCB will indicate “Outdoor Unit DC motor error” when it detects imbalanced current on the three lead wires of the driving motor.</p> <p>Inspection path: Is the DC motor stuck by foreign matters→Motor terminal connectors→Outdoor Unit main PCB→Motor</p>
-----------------------------	--

Tools required for inspection	Outdoor Unit main PCB in normal condition
Common faulty components	Mechanical jam of Outdoor Unit motor, Outdoor Unit main PCB, Outdoor Unit DC motor
Inspection procedure and key points	<ol style="list-style-type: none"> 1. First exclude the possibility of mechanical jam of Outdoor Unit motor blades. . 2. Observe if the terminal of the motor is not connected firmly or the order of lead wires is correct. If the Outdoor Unit motor of the newly installed air conditioner rotates reversely, first observe if the color order of the three lead wires is correct, or change the order of any two of the three lead wires of the motor to see if the motor can rotate in the forward direction. 3. The DC motor of this scheme is relatively simple and reliable, so the problem is more likely to be caused by the drive part of the motor of the Outdoor Unit main PCB. The maintenance personnel may as well prepare matched Outdoor Unit main PCB before maintenance. If the motor returns to normal after replacing the main PCB, then it's the main PCB problem; if it still indicates Outdoor Unit DC motor error, then replace the Outdoor Unit DC motor.
Special attention	Unlike the 5-core Indoor Unit DC motor, there will be a process of motor blade position locking before the 3-core DC motor with Outdoor Unit drive starts to rotate. The motor blades will shake mechanically for 3-5 seconds and then rotate slowly, which is normal phenomenon.

(10) F1 -Module protection error

Explanation of error	<p>Cause: The power module is the part to directly drive the compressor to work. It can protect the machine in time when overcurrent, overvoltage or overheat occurs and stops the compressor from working. It will, at the same time, send “shutdown request” to the module panel. The error triggered by the “shutdown request” is called “module protection error”.</p> <p>Inspection path: Supply voltage → Compressor wire, reactor wire → System blocked → Module panel damaged → Outdoor Unit main PCB destroyed → Compressor destroyed</p>
Tools required for inspection	Multimeter, pressure gauge, megameter, module panel in normal condition
Common faulty components	Supply voltage, compressor wire, reactor, system pressure, module panel, Outdoor Unit main PCB, compressor

<p style="text-align: center;">Inspection procedure and key points</p>	<ol style="list-style-type: none"> 1. Is the order of compressor wires not correct, which makes the compressor rotate reversely? Try exchanging the compressor wires on U-V phase to see if the problem can be solved? 2. Check if the supply voltage is unstable and highly volatile, and test if the system pressure is normal. High system pressure will cause rotating problems to the compressor. 3. Is the module panel fixed to the radiator firmly? Will it cause pool cooling? Is the Indoor Unit and Outdoor Unit heat exchanger dirty, which lead to poor heat transfer and high system pressure? 4. If “module protection error” will be indicated immediately after starting up, it is almost certain that it’s substantial error, having nothing to do with supply voltage and system pressure, it is suggested to observe if there is any component destroyed by strike arc near the module panel; use the multimeter to test if the resistances between any two compressor wires are the same. The resistances between any two compressor wires in normal condition are tiny resistances at ohm level and are basically equal; then use the megameter to measure if the resistance insulation of the three compressor wires against the earth wire is good (normally at MΩ level), and check if the reactor wire is well connected or the reactor is destroyed. 5. Test if the 15V and 5V (3.3V) power supply on the module panel is stable and exclude the module panel error caused by power supply of the Outdoor Unit main PCB. 6. Methods for judging whether the power module is damaged: use the “diode position” of the multimeter to measure the features of P of the module panel against U-V-W three phases respectively. Measure the power module P-U, P-V and P-W, there is always infinite resistance at one side and fixed on-state voltage at the other side (generally 0.5V); measure the features between N-U, N-V and N-W in the same way, if short circuit occurs during any measurement, then the module is destroyed. 7. Replace with the module panel in normal condition for test. If the test is normal after changing the module panel, then the original module panel is destroyed. 8. After excluding problems of module, connecting wires, system and power supply, distinguish by ear. If there is only electromagnetic sound and the compressor does not work; or the sound of irregular running appears after the compressor works for a while and then it shuts down and indicates error; chances are that the compressor is blocked or destroyed, consider replacing the compressor.
---	--

(11) F2- PFC protection error

<p>Explanation of error</p>	<p>Cause: PFC board is a component of the inverter air conditioner for power factor correction and voltage boosting. When the PFC board cannot perform power calibration as normal because of overcurrent and overvoltage, it will indicate “PFC protection error” and its function may also be integrated with the module panel or main PCB. Inspection path: Supply voltage→AC and DC power path→PFC board data wire→PFC board→Main PCB</p>
<p>Tools required for inspection</p>	<p>Multimeter, PFC board in normal condition</p>
<p>Common faulty components</p>	<p>Supply voltage, reactor, PFC board, module panel, Outdoor Unit main PCB</p>
<p>Inspection procedure and key points</p>	<ol style="list-style-type: none"> 1. Check if the supply voltage is unstable and highly volatile or the voltage is too low (below AC 135V) 2. The reactor is one of core parts of PFC. Check if the reactor itself is destroyed and the reactor connecting wire is in poor connection, which makes PFC functions not performed. Do not remove the reactor and replace with short circuit by no means. 3. If “PFC protection error” will be indicated immediately after starting up, it is almost certain that it’s substantial error, having nothing to do with supply voltage, it is suggested to observe if there is any component destroyed by strike arc near the module panel 4. Test if the 15V and 5V (3.3V) power supply on the PFC board is stable and exclude the PFC board error caused by power supply of the Outdoor Unit main PCB. 5. Replace with the PFC board in normal condition for test. If the test is normal after changing the PFC board, then the original PFC board is destroyed. 6. The possibility that there is something wrong with 15V or 5V power of the module panel that causes the control power supply problem of the PFC board is not excluded. 7. Some module panels integrate PFC function and compressor drive function in one, so just replace with an integrated module panel. 8. For single-panel single-chip main PCBs, if PFC protection error appears, and there is no problem in supply voltage, reactor connection or reactor, just replace the controller of the Outdoor Unit.

(12) F3- Compressor out-of-step error

<p>Explanation of error</p>	<p>Cause: The module panel will constantly test the current of lead wires of the compressor and calculate the position of the rotator of the compressor when driving the compressor to work. When the compressor deviates far from the normal operating status, it will indicate “compressor out-of-step error” because the current of the compressor wires is too high or it cannot detect the position of the rotator. This error always follows “module protection error”, so they have similar inspection methods.</p> <p>Inspection path: supply voltage→Compressor wire, reactor wire→System blocked→Module panel damaged→Outdoor Unit main PCB destroyed→Compressor destroyed</p>
<p>Tools required for inspection</p>	<p>Multimeter, pressure gauge, module panel in normal condition</p>
<p>Common faulty components</p>	<p>Supply voltage, compressor wire, reactor, system pressure, module panel, Outdoor Unit main PCB, compressor</p>
<p>Inspection procedure and key points</p>	<ol style="list-style-type: none"> 1. Is the order of compressor wires not correct, which makes the compressor rotate reversely? Try exchanging the compressor wires on U-V phase to see if the problem can be solved? 2. Check if the supply voltage is unstable and highly volatile, and test if the system pressure is normal. High system pressure will cause rotating problems to the compressor. 3. Is the module panel fixed to the radiator firmly? Will it cause pool cooling? Is the Indoor Unit and Outdoor Unit heat exchanger dirty, which lead to poor heat transfer and high system pressure? 4. If “compressor out-of-step error” will be indicated immediately after starting up, it is almost certain that it’s substantial error, having nothing to do with supply voltage and system pressure, it is suggested to observe if there is any component destroyed by strike arc near the module panel; use the multimeter to test if the resistances between any two compressor wires are the same. The resistances between any two compressor wires in normal condition are tiny resistances at ohm level and are basically equal; then use the megameter to measure if the resistance insulation of the three compressor wires against the earth wire is good (normally at MΩ level), and check if the reactor wire is well connected or the reactor is destroyed. Check if the DC voltage between P-N is too high (above 200V). 5. Test if the 15V and 5V (3.3V) power supply on the module panel is stable and exclude the module panel error caused by power supply of the Outdoor Unit main PCB. 6. Replace with the module panel in normal condition for test. If the test is normal after changing the module panel, then the original module panel is destroyed. 7. After excluding problems of module, connecting wires, system and power supply, distinguish by ear. If there is only electromagnetic sound and the compressor does not work; or the sound of irregular running appears after the compressor works for a while and then it shuts down and indicates error; chances are that the compressor is blocked or destroyed, consider replacing the compressor.

Special attention	For the “compressor out-of-step error” and “module protection error”, the former is calculated by the main chip of the module panel and the latter is detected by the power module itself. They are abnormal operating phenomenon of the compressor essentially. If there is uncertainty about either error, analyze both together with similar method. For inverter air conditioners that are in poor electrical environment or are old, occasional occurrence of such errors is a normal protection.
--------------------------	--

(13) F4- Discharge sensor error

Explanation of error	Cause: The Outdoor Unit main PCB will indicate “discharge sensor error” and send it to the Indoor Unit main PCB when it detects short circuit or open circuit of the discharge sensor. Inspection path: Discharge sensor→Sensor wire→Connectors→Outdoor Unit main PCB
Tools required for inspection	Multimeter, 50KΩ standard discharge sensor (25℃)
Common faulty components	Discharge sensor, Outdoor Unit main PCB
Inspection procedure and key points	<ol style="list-style-type: none"> 1. Check if there is any evident resistance problem in the sensor. Whether in short circuit or open circuit, the resistance should maintain in a reasonable range (about 50KΩ when the compressor is not working and between 3 KΩ and 30 KΩ after the compressor works for a while, the corresponding discharge temperature should be 100℃ -38℃). 2. Check if the sensor wire or the sensor connecting wire is damaged. 3. Check if the connecting terminal is connected firmly, the weld between the terminal and the main PCB is loose; pull the terminal slightly for inspection if necessary. 4. Check whether the sensor is affected with damp. The coil sensor is quite easy to be affected with damp in case the lead wire of coil sensor is above the copper pipe. 5. If there is no standard sensor at hand, exchange the discharge sensor with the one beside it to see if the error changes. If yes, there is something wrong with the sensor and it should be replaced; if it still indicates “Outdoor Unit coil sensor error”, replace the Outdoor Unit main PCB.
Special attention	Most discharge sensors have a standard resistance of 50KΩ (25℃). Do not use improper sensor during maintenance, or the machine will sense the discharge temperature mistakenly and enters the protection state frequently. For example, in the case where replace the 20KΩ coil sensor for the discharge sensor by mistake, the discharge temperature that the Outdoor Unit main PCB senses will be higher than the actual discharge temperature, which will make normal air conditioners enter the high discharge temperature protection state frequently, and the compressor frequency threshold will rise and lead to shutdown of the compressor.

(14) F5 -Compressor top head sensor error

Explanation of error	<p>Cause: The compressor top head sensor is a compressor top head temperature protection switch most of the time. It keeps closed (short circuit) when the compressor temperature is normal and switches off (open circuit) when the temperature is too high. The Outdoor Unit main PCB will indicate “compressor top head sensor error” when it senses disconnection of the compressor top head protection switch.</p> <p>Inspection path: Compressor top head sensor (temperature protection switch)→Sensor wire→Connectors→Outdoor Unit main PCB</p>
Tools required for inspection	Pressure gauge, multimeter
Common faulty components	System pressure, liquid deficiency, compressor top head sensor (temperature protection switch), Outdoor Unit main PCB
Inspection procedure and key points	<ol style="list-style-type: none"> 1. First check if the compressor top head temperature is too high (above 110°C) and causes action of the compressor top head sensor (temperature protection switch); reasons why the compressor top head temperature is too high may be: the system is deficient in liquid and the compressor idles; the system is blocked and the pressure of the compressor is too high. 2. After excluding the possibility of the system problem, please note that the temperature protection switch is closed normally. Test if the terminals of the sensor are in the short-circuit condition with the multimeter. In the case of open circuit, then there is something wrong with the sensor or lead wires. 3. Check if the sensor wire or the sensor connecting wire is damaged. 4. Check if the connecting terminal is connected firmly, the weld between the terminal and the main PCB is loose; pull the terminal slightly for inspection if necessary. 5. Disconnect the power supply and short circuit a metal with the compressor top head terminal of the Outdoor Unit main PCB. If the compressor top head sensor error disappears after start up, then replace the sensor; if the error still occurs, it’s probably the main PCB problem, replace the Outdoor Unit main PCB.
Special attention	The compressor top head sensor is just a temperature switch which is highly reliable and is less likely to go wrong generally. Pay more attention to the system pressure and the compressor temperature.

(15) F6- Outdoor Unit temperature sensor error

Explanation of error	<p>Cause: The detection of short circuit or open circuit of Outdoor Unit temperature sensor during the inspection of Outdoor Unit main PCB, indicated by "Outdoor Unit temperature sensor error".</p> <p>Inspection path: Sensor→Sensor wire→Connectors→Outdoor Unit main PCB</p>
-----------------------------	---

Tools required for inspection	Multimeter, 15K Ω standard sensor (25 $^{\circ}$ C)
Common faulty components	Outdoor Unit temperature sensor, Outdoor Unit main PCB.
Inspection procedure and key points	<ol style="list-style-type: none"> 1. Check whether there's resistance problem, short circuit or open circuit in the sensor; the resistance value shall be within a reasonable range (15KΩ under the temperature of 25$^{\circ}$C). 2. Check whether the sensor wire is broken. 3. Check whether the terminal connectors are well fixed; check whether the weld between the terminal and the main PCB is loose, and pull the terminal slightly for inspection if necessary. 4. Check whether the sensor is affected with damp. 5. In case no standard sensor is available at present, replace the Outdoor Unit temperature sensor with the other sensor asides, and then check whether the error still exists; if the error disappears, replace the sensor; if the error still exists, it's possible that the main PCB is faulted, change the Outdoor Unit main PCB.
Special attention	Most of the standard resistance values of the Outdoor Unit temperature sensors are 15K Ω (hen temeprature is at 25 $^{\circ}$ C), and the higher the temeprature is, the lower the resistance value is, and the lower the temperature is, the higher the resistance value is. Do not use improper sensor during repairing and maintenance, or it may led to the wrong temperature sensing of the machine.

(16) F7-OVP or UVP error

Explanation of error	<p>Cause: All the inverter air conditioners are equipped with voltage inspection circuits, but differnt models of machines have differnt locations for the voltage inspection (on the modue panel or Outdoor Unit main PCB). When the supply voltage is lower than 135V or higher than 275V, the inspectio circuit would detect over or under voltage protection signal and send it to the Outdoor Unit main PCB and the Outdoor Unit main PCB would raise the alarm "OVP or UVP error" and indicate it through the Indoor Unit motor.</p> <p>Inspection path: supply voltage \rightarrow Indoor Unit direct current voltage \rightarrow reactor wiring \rightarrow module panel \rightarrow Outdoor Unit main PCB.</p>
Tools required for inspection	Multimeter
Common faulty components	Supply voltage, reactor, moduel panel and Outdoor Unit main PCB.

Inspection procedure and key points	<p>1. First, check the supply environment of the user, especially shall check when the compressor of the air conditioner has been running for a while. The normal supply voltage shall be between 198V and 242V and the minimum work assurance range of the air conditioner shall be within 165V and 265V and it shall be especially noted that the voltage value shall not be decreased significantly after running of the compressor (voltage decreasing by over 25V), because if the supply voltage is decreased by a lot, it means the supply line capacity is insufficient and the user is usually suggested to replace the circuit or install a specizlied air conditioner supply voltage stabilizer.</p> <p>2. For the Outdoor Unit machines with PFC panels (without separate rectifier bridges), the operator shall ensure if the PFC function is on with the direct current voltage grade of the multimeter. When the compressor is running, voltage between P and N ends detected on the test module panel or Outdoor Unit main PCB shall be over 200V and if the voltage is below that range, it is possible that the reactor is faulted or the PFC is broken.</p> <p>3. When the air conditioner is switched on, if the compressor is not running but there is a alarm of "OVP or UVP error" and the power voltage detected with the multimeter is not below 150V, it's probably the voltage inspection circuit is faulted. The operator shall check and confirm the voltage inspection circuit is on which PCB first and then replace it. The regular replacement: for the Outdoor Unit machine of single panel single chip, replace the Outdoor Unit controller directly; and for the machine of two panels, replace the module panel.</p>
Special attention	<p>For some models, OVP or UVP error signal is delivered through the connector wires between the module panel and the Outdoor Unit main PCB, thus it is possible the voltage signal is not delivered when the communication between teh module panle and the Outdoor Unit main PCB is not good. It is possible that the error is fause raised but after some minutes that the error is finally confirmed as "Outdoor Unit main PCB and module pannel communication error", which shall be specially noted.</p>

(17) F8-Outdoor Unit main PCB and module panel communication error (exclusive of Outdoor Unit machine of single panel)

Explanation of error	<p>Cause: Only the models with the module panels separated with the Outdoor Unit main PCBs may have this error. When the machine is running normally, the module panel and the Outdoor Unit main PCB would coordinate with each other on the communication to work and when the communication is off, the Outdoor Unit main PCB would raise the alarm of "main PCB and module panel communication error". Only "module panel, data line and Outdoor Unit main PCB" are related to such communication.</p> <p>Inspection path: data line connection → module panel power →module panel →Outdoor Unit main PCB</p>
Tools required for inspection	<p>Multimeter and regular module panel.</p>

Common faulty components	Module panel and main control data line, module panel and Outdoor Unit main PCB.
Inspection procedure and key points	<ol style="list-style-type: none"> 1. First check if the communication connection line (mostly 4 chips) between the module panel and main control panel gets loose and if the connection is faulted. 2. Measure and check with a multimeter if the power from the Outdoor Unit main PCB is normal and especially note that if the 5V (3.3V) power is led to the module panel. Eliminate the possibility that it's not running normally because there is no 5V (3.3V) power at the module panel. 3. The maintenance personnel shall replace the module panel of the faulted air conditioner with a regular module panel taken with him and if the communication error disappears when the Outdoor Unit machine is switched on, it means the original module panel is faulted and if the error is still there, maybe the Outdoor Unit main PCB shall be replaced.

(18) F9- outdoor EE error

Explanation of error	<p>Cause: Many parameters need to be preset for the running of the Outdoor Unit of the air conditioner and such parameters are placed in a data storage 8-foot chip, which is called "EEPROM" or "EE" for short. The motor on the Outdoor Unit main PCB can only work after reading the data stored in EE and if not read, the alarm "outdoor EE error" would be reported and raised in the Indoor Unit machine. Reasons for data not being read are as follows:</p> <ol style="list-style-type: none"> 1. wrong EE chip data format; 2. EE chip is broken; 3. bad contact of EE or fault of EE reading circuit; 4. backward installation of EE chip. <p>Inspection path: Outdoor Unit main PCB.</p>
Tools required for inspection	None.
Common faulty components	Bad contact of EE, Outdoor Unit main PCB.
Inspection procedure and key points	<ol style="list-style-type: none"> 1. Replace the Outdoor Unit main PCB directly.

(19) FA- recirculated sensor error (only models of electronic expansion valves are involved)

<p>Explanation of error</p>	<p>Cause: The recirculated sensors are only used on machine models of electronic expansion valves and the back temperature value is considered as the basis for adjustment of the electronic expansion valve and determination if the four-way valve changes the position normally during heating. When the main PCB detects open circuit or short circuit of the recirculated sensor, it would raise an alarm of "recirculated sensor error" and send it to the Indoor Unit main PCB to indicate it.</p> <p>Inspection path: four-way valve →recirculated sensor → sensor wire → connectors → Outdoor Unit main PCB</p>
<p>Tools required for inspection</p>	<p>Multimeter, pressure meter, normal 20KΩ recirculated sensor</p>
<p>Common faulty components</p>	<p>Four-way valve, recirculated sensor, Outdoor Unit main PCB.</p>
<p>Inspection procedure and key points</p>	<ol style="list-style-type: none"> 1. If the error appears in heating but not in cooling, first check if the four-way valve failed to change the position or there is a back flow, which can be estimated by measuring the high and low pressures with the pressure meter; for the consideration of electricity control, we can use a multimeter. During heating, check if the four-way valve terminal can switch a circuit of 220V, if yes and the four-way valve still is faulted in the position changing, the four-way valve is faulted; and if there is no circuit over 220V in heating, it means the Outdoor Unit main control valve is faulted. 2. If it is not the four-way valve that is faulted, check on the resistance value and short circuit problems and the resistance value shall be within a proper range (around 20KΩ at temperature of 25°C). 3. Check whether the terminal connectors are well fixed; check whether the weld between the terminal and the main PCB is loose, and pull the terminal slightly for inspection if necessary. 4. Check whether the sensor is affected with damp. For the recirculated sensor, if the led is on the above and thecopper pipe is below, it is possible to be damped. 5. The maintenance personnel can replace the possibly faulted recirculated sensor with a normal one and if the error disappears, it means the original recirculated sensor is faulted and needs to be replaced; and if the error is still there, consider to replace the Outdoor Unit main PCB.

(20) P2 - High-pressure protection

Explanation of error	<p>Cause: In standby state or when the equipment is running, the High-pressure switch is disconnected three times (within 20 minutes) and reported as "High-pressure protection"; Inspection path: High-pressure switch cable → connector → High-pressure switch → main PCB</p>
Tools required for inspection	<p>Multimeter, connectoin line and High-pressure swtich</p>
Common faulty components	<p>High-pressure swtich connectoin line, fluorine deficiency of unit and High-pressure swtich</p>
Inspection procedure and key points	<ol style="list-style-type: none"> 1. Check whether the plug-in terminals are firmly connected and whether the terminals and the main PCB are welded loosely. If necessary, gently pull them to check; 2. Use a multimeter to measure whether it is disconnected; 3. Use the multimeter to check the state of the High-pressure swtich and check whether it is in the OFF state (normally OFF, unusual disconnection); 4. If the pressure is normal and the High-pressure swtich is kept open, it is positive that the pressure voltage is faulted; 5. If the pressure swtich is normal and the connection line is tact and the failure is still reported, replace the corresponding main PCB.
Special attention	<p>The reason why High-pressure swtiches are often disconnected is the leakage of equipment. When the high voltage swtich is off, first check whether the air conditioner's pressure is normal. If it is normal but the failure is still displayed aftere replacing the Outdoor Unit main PCB, it is possible that the connecting pipe may be too long or the Outdoor Unit ambinet temperature is too low</p>

(21) P3 –Liquid Leakage Protection

Explanation of error	<p>Cause: The liquid volume of the system is less than 30%, which leads to non-refrigeration and liquid shortage protection. Inspection path: whether the valves of the outdoor unit are opened → whether the evaporator, condenser, connectoin pipe are damaged or cracked → whether the environmental temperature sensor and the coil temperature sensor are damaged at the same time</p>
Tools required for inspection	<p>Hex nut, multimeter, pressure gauge</p>

Common faulty components	Stop valve, evaporator, condenser and connection pipe
---------------------------------	---

(22) P4 –Refrigeration Overload Protection

Explanation of error	<p>Cause: Outdoor coil sensor senses excessive temperature, prevents compressor from overloading, and reduces frequency.</p> <p>Inspection path: the system is dirty or blocked → the condenser is dirty → Outdoor Unit coil sensor is faulted → AC motor not running → failure of divider resistance of controller</p>
Tools required for inspection	Multimeter and pressure gauge
Common faulty components	Coil sensor, condenser and outdoor unit controller
Inspection procedure and key points	<ol style="list-style-type: none"> 1. Check the coil sensor with a multimeter to see if the resistance value is normal (20KΩ standard sensor, 25°C) 2. Use a pressure gauge to detect system pressure. If the system pressure is high, it may cause Indoor Unit dirty blockage or poor Outdoor Unit heat transfer, which may lead to high coil temperature. 3. Observe whether the speed of AC motor is too low, which leads to poor heat transfer and high coil temperature. 4. Use a multimeter to check whether the voltage dividing resistance of temperature sensor circuit of Outdoor Unit controller coil is abnormal. If you don't know how to measure it, try to replace the Outdoor Unit controller to check whether it returns to normal state.

(23) P5–Discharge Protection

Explanation of error	<p>Cause: the discharge sensor detects that the discharge temperature is too high and triggers the discharge protection shutdown.</p> <p>Inspection path: system pressure → indoor / outdoor air inlet → discharge sensor → Outdoor Unit panel</p>
Tools required for inspection	Multimeter, pressure gauge, regular 50K Ω exhaust sensor (25°C)
Common faulty components	Indoor coil sensor

<p>Inspection procedure and key points</p>	<ol style="list-style-type: none"> 1. Check if the system pressure is low, if is, usually it the shortage of liquid that leads to excessive discharge temperature protection; 2. Check whether the indoor/outdoor air inlet is blocked, such as whether the evaporator or condenser is dirty or whether the filter is dirty or blocked and if inlet is affected, remove the shield. 3. Check whether the air volume at the teh tuyere is too small, observe whether the Indoor Unit fan blades are dirty blocked, and if dirty blocked blades are found, clean the blades. 4. Measure the resistance drift of the discharge sensor with a multimeter at ambient temperature.
---	--

(24) P6–Indoor High Temperature Protection

<p>Explanation of error</p>	<p>Cause: Protection shutdown due to temperature of indoor coil. Inspection path: indoor air inlet → indoor unit filter → indoor motor → indoor coil sensor</p>
<p>Tools required for inspection</p>	<p>Multimeter, pressure gauge, regular 20K Ω exhaust sensor (25°C)</p>
<p>Common faulty components</p>	<ol style="list-style-type: none"> 1. Check whether the indoor air inlet is blocked or not, if it affects the wind, remove the shield; 2. Check whether the filter is dirty or not. If dirty blockage is found in the filter, clean the filter. 3. Check if the air volume at teh tuyere is too small and if the indoor unit fan is blocked, if is, clean the fan. 4. Measure the drift of the inner disk sensor with a multimeter at ambient temperature.
<p>Inspection procedure and key points</p>	<p>P6 usually refers to the high temperature protection of the Indoor Unit heating coil due to poor air inlet.</p>

(25) P7–Anti-freezing Protection in Refrigeration Room

<p>Explanation of error</p>	<p>Cause: Protection shutdown due to temperature of indoor coil. Inspection path: indoor air inlet → indoor unit filter → indoor motor → indoor coil sensor</p>
<p>Tools required for inspection</p>	<p>Multimeter, pressure gauge, regular 20K Ω exhaust sensor (25°C)</p>

Common faulty components	Indoor coil sensor
Inspection procedure and key points	<ol style="list-style-type: none"> 1. Check whether the indoor air inlet is blocked or not, if it affects the wind, remove the shield; 2. Check whether the filter is dirty or not. If dirty blockage is found in the filter, clean the filter. 3. Check if the air volume at teh tuyere is too small and if the indoor unit fan is blocked, if is, clean the fan. 4. Measure the drift of the inner disk sensor with a multimeter at ambient temperature.
Special attention	P7 usually refers to the anti-freezing protection of the refrigeration room due to poor air inlet.

(26) P8–Overcurrent Protection

Explanation of error	<p>Cause: Controller detects AC bus current exceeding the set protection value, then limits and reduces the frequency.</p> <p>Inspection path: system blockage → grid voltage → outdoor unit controller</p>
Tools required for inspection	Multimeter, pressure gauge
Common faulty components	Grid voltage and outdoor unit controller
Inspection procedure and key points	<ol style="list-style-type: none"> 1. Use a mutlimeter to detect and check if the bus voltage is too low, causing the overcurrent protection. 2. Use a pressure gauge to check whether the pressure of the system exceeds the standard. If the pressure exceeds the standard, it may lead to dirty blockage of the system. 3. Replace the outdoor unit controller and if the unit returns to normal, it is the problem of the controller.
Special attention	Generally, such protection occurs at high load, but should not occur at low load and low temperature, and the priority of this protection is after the protection of refrigeration against overload and discharge.

(27) L0- Dc overvoltage error

Explanation of error	Cause: Voltage too low or too high, or suddenly change of voltage
Tools required for inspection	Multimeter
Common faulty components	ODU PCB board
Inspection procedure and key points	<ol style="list-style-type: none"> 1. Check if the voltage is too low or too high, and if there is suddenly change of voltage 2. Check if there is any broken of ODU PCB board After check mentioned 2 steps, if the L0 error is still occur, pls check as the guidance of Error code “F1”.

(28) L1- Compressor Phase current overcurrent protection

L2- Compressor Lost step protection

Explanation of error	Cause: ODU PCB board broken, voltage too low or too high, or suddenly change of voltage, connecting wire is broken, compressor issue
Tools required for inspection	Multimeter
Common faulty components	Connecting wire, external main control panel, compressor
Inspection procedure and key points	<ol style="list-style-type: none"> 1. Check the ODU PCB board if there is any broken; 2. Check whether the connecting wire is broken; 3. Check whether the compressor terminal line is connected wrongly; whether the compressor is blocked, whether the system pressure is too high; After check mentioned 3 steps, if the L1 or L2 error is still occur, pls check as the guidance of Error code “F1”.

(29) L3- Compressor phase error

Explanation of error	Cause: mainly because the compressor wire wrongly connected
Common faulty components	Compressor wire

(30) L4-Compressor drive module IPM fault

Explanation of error	Cause: mainly because the compressor wire wrongly connected
-----------------------------	---

Tools required for inspection	Multimeter
Common faulty components	Supply voltage, compressor wire, system pressure, ODU PCB board, compressor
Inspection procedure and key points	<ol style="list-style-type: none"> 1. Check the ODU PCB board if there is any broken; 2. Check the compressor connecting wire if the wire is broken, or not connect fasten. 3. Check the compressor if there is any broken. <p>After check mentioned 3 steps, if the L4 error is still occur, pls check as the guidance of Error code “F1”.</p>

(31) L5- PFC overcurrent hardware protection

L6- PFC overcurrent software protection

L7- Current detection AD abnormal protection

LC- PFC current detection AD abnormal protection

Ld- Dc fan motor detection AD abnormal protection

Explanation of error	Cause: ODU PCB board broken, voltage too low or too high, or suddenly change of voltage
Tools required for inspection	Multimeter
Common faulty components	Supply voltage
Inspection procedure and key points	<ol style="list-style-type: none"> 1. Check the ODU PCB board if there is any broken; 2. Check if the voltage is too low or too high, and if there is suddenly change of voltage <p>After check mentioned 2 steps, if the error is still occur, pls check as the guidance of Error code “F1”.</p>

(32) L8- shunt Resistance imbalance fault

Explanation of error	Cause: ODU PCB board broken, connecting wire broken or connected loose, compressor issue
Tools required for inspection	Multimeter
Common faulty components	Supply voltage, connecting wire, system pressure, module board, ODU PCB board, compressor

Inspection procedure and key points	<ol style="list-style-type: none"> 1. Check the ODU PCB board if there is any broken; 2. Check the connecting wire if the wire is broken, or not connect fasten. 3. Check the compressor if there is any broken. <p>After check mentioned 3 steps, if the L8 error is still occur, pls check as the guidance of Error code “F1”.</p>
--	---

(33) L9- IPM temperature sensor error

Explanation of error	Cause: ODU PCB board broken, Wind speed of ODU fan is abnormal, high system pressure
Tools required for inspection	Multimeter
Common faulty components	System pressure, ODU PCB board, ODU fan
Inspection procedure and key points	<ol style="list-style-type: none"> 1. Check the ODU PCB board if there is any broken; 2. Check whether the wind speed of ODU fan is abnormal; 3. Check if system pressure is too high; <p>After check mentioned 3 steps, if the L9 error is still occur, pls check as the guidance of Error code “F1”.</p>

(34) LA- Compressor startup failure

Explanation of error	Cause: ODU PCB board broken, connecting wire broken or connected loose, compressor issue
Common faulty components	Supply voltage, connecting wire, system pressure, module board, ODU PCB board, compressor
Inspection procedure and key points	<ol style="list-style-type: none"> 1. Check the ODU PCB board if there is any broken; 2. Check the connecting wire if the wire is broken, or not connect fasten. 3. Check the compressor if there is any broken. <p>After check mentioned 3 steps, if the L8 error is still occur, pls check as the guidance of Error code “F1”.</p>

(34) LE- DC fan motor phase error

LF- DC fan motor Lost step protection

Explanation of error	Cause: ODU PCB board broken, voltage too low or too high, plug too loose, module error, DC fan error
Common faulty components	ODU PCB board, module, DC fan

<p>Inspection procedure and key points</p>	<p>1. Check the ODU PCB board if there is any broken; 2. Check whether the wind speed of external fan is abnormal; 3. Check if system pressure is too high; After check mentioned 3 steps, if the L9 error is still occur, pls check as the guidance of Error code “F1”.</p>
---	---

(36) LH- DC fan motor IPM protection

<p>Explanation of error</p>	<p>Cause: ODU PCB board broken, voltage too low or too high, The connecting wire is broken, module board error, the condenser is blocked.</p>
<p>Common faulty components</p>	<p>connecting wire, voltage, module, condenser</p>
<p>Inspection procedure and key points</p>	<p>1. Check the ODU PCB board if there is any broken; 2. Check the connecting wire if the wire is broken, or not connect fasten; 3. Check whether the dc fan is damaged; 4. Check whether the condenser is blocked; After check mentioned 3 steps, if the LH error is still occur, pls check as the guidance of Error code “F1”.</p>

8-2 Troubleshooting for Normal Malfunction

24 The Foremost Inspecting Items

- ① The input voltage must be within +10% tolerance of the rated Voltage. If it is not the case, the air-conditioner will probably not work normally.
- ② Check the connecting cord between indoor unit and outdoor unit to see if it is properly connected. The connecting must be done according to the wiring diagram, please also notice that even different models may have the connecting cord of the same specification. Please check if the marks at the connecting terminal and the marks on the cord can match, otherwise, the air-conditioner will not work normally.
- ③ If the following phenomena are found, the problem is not from the air-conditioner itself.

NO.	Problems	Causes
1	The motor is heard operating but the air-conditioner does not work when the indoor unit is powered on	Since the air-conditioner is powered on, it will come to working condition as long as you press the ON/OFF button of the remote control and the Signal is well received.
2	The compressor stops running but the indoor motor keeps working when it is at cooling mode with the indoor temperature higher than set temperature.	If you turn off the air-conditioner and restart it immediately, it will return to normal in 3 minutes, after that, the air-conditioner will automatically adjust the indoor motor speed to what you set.
3	The compressor works discontinuously at dehumidifying mode.	The air-conditioner will automatically control the working of the compressor according to the inside temperature.
4	The air-conditioner does not work while the LED display is on.	The TIMER is set with the A/C; it will be in hold on condition. If the TIMER setting is cancelled, the air-conditioner will return to normal working condition.
5	The compressor works discontinuously at cooling and dehumidifying mode, and the indoor motor slows down.	The compressor stops Indoor Unit or the motor slows down to prevent the indoor heat exchanger from being frozen.

25 Fault Diagnosis by Symptom

① No Power Display

(1) Items

- a) Check if the input voltage is correct?
- b) Check if the AC power supply connecting is correct?
- c) Check if the output voltage of the manostat L7805 (IC2) is correct?

(2) Trouble shooting procedure

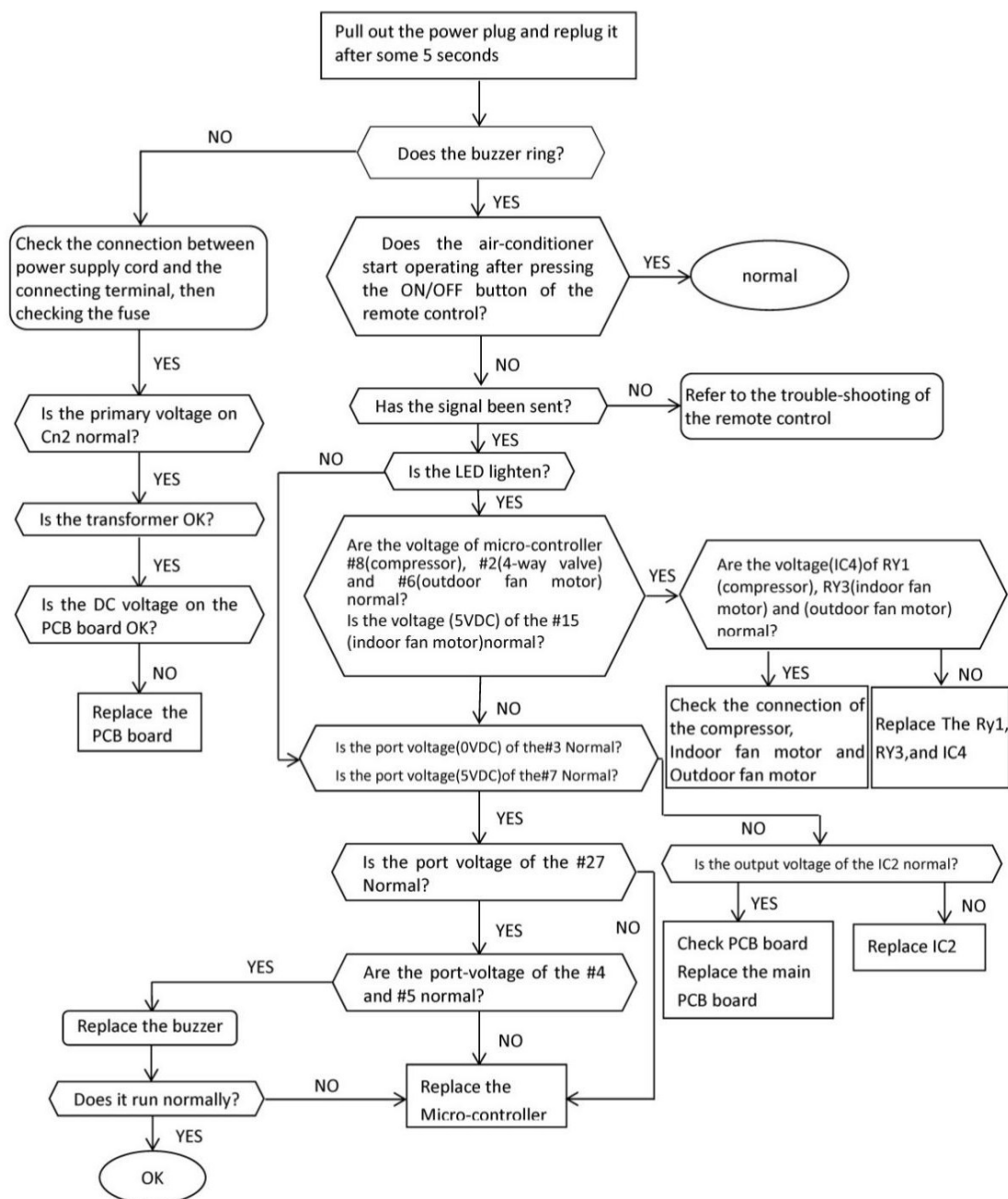

②The Indoor Motor Does Not Work

(1) Items

- Check if the indoor motor is connected correctly to the connector (CN8)?
- Check if the AC input voltage is correct?
- Check if the IC of indoor motor is connected correctly to the connector (CN2)?
- Check if the capacity of indoor motor is connected correctly to the connector (CN8)?

(2) Trouble shooting procedure

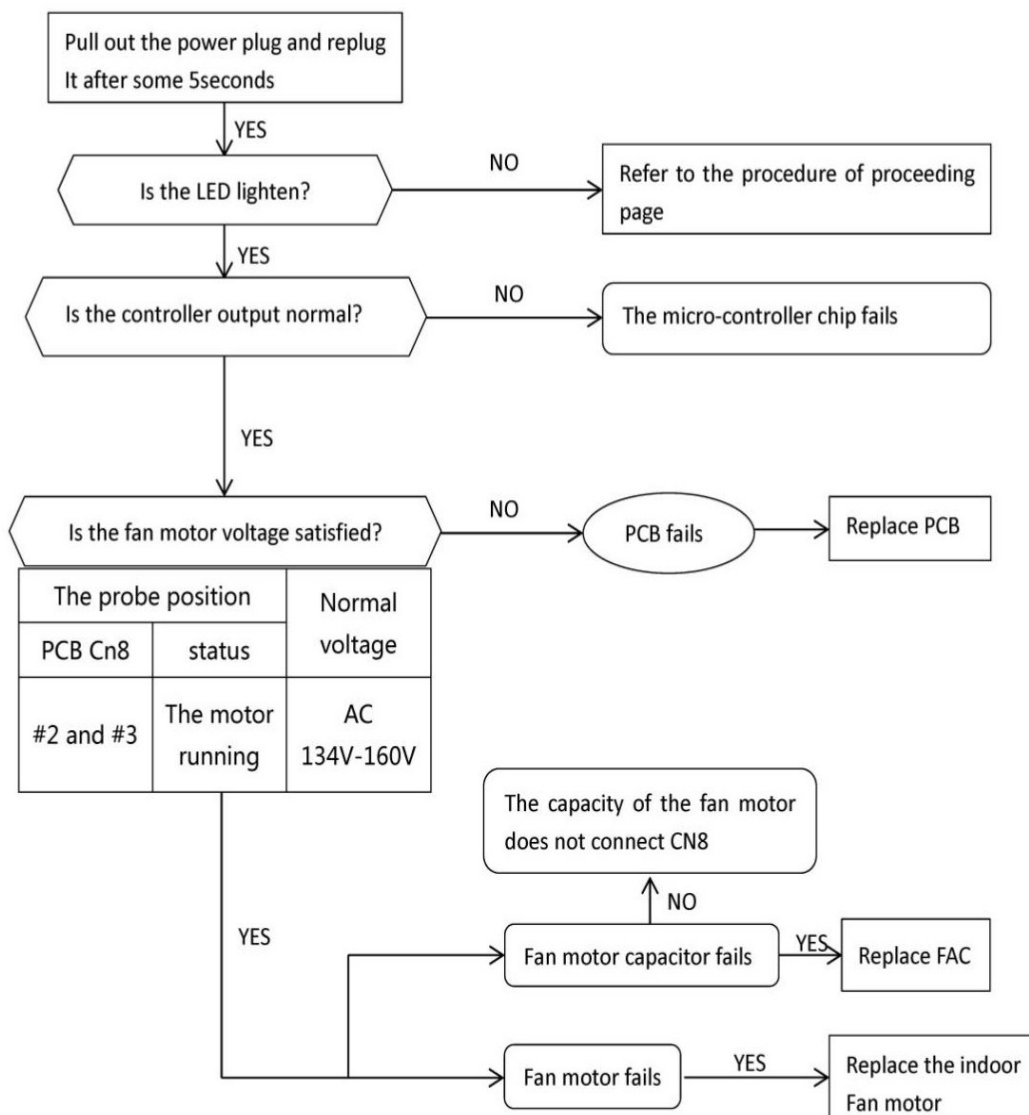

③The Outdoor Unit Does Not Work

(1) Items

- a) Check if the input voltage is correct?
- b) Check if the wire connection of the outdoor connecting terminal is correct?

(2) Trouble shooting procedure

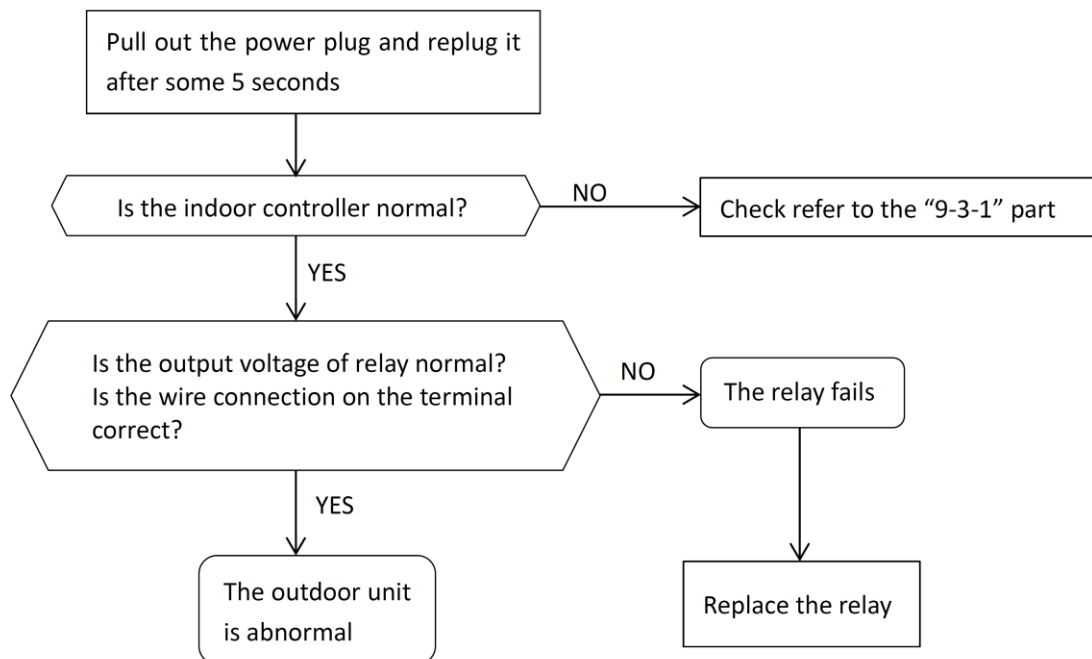

④The Step Motor Does Not Work

(1) Items

a) Check if the input voltage is correct?

b) Check if the step motor controlling the up-down movement firmly connected to Cn2?

(2) Trouble shooting procedure

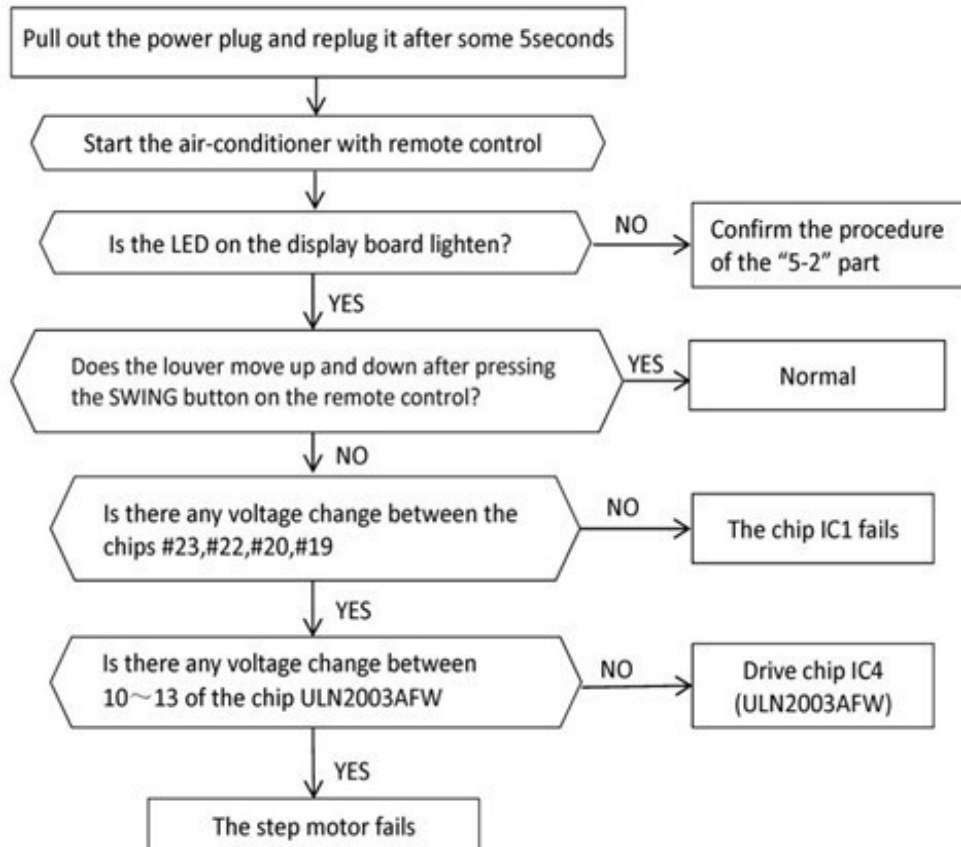

⑤ Heating Mode Can Work, But No Hot Air Blow

- (1) Check if the set temperature is lower than the indoor temperature?
- (2) Check if the indoor PCB is connected to the terminal correctly?

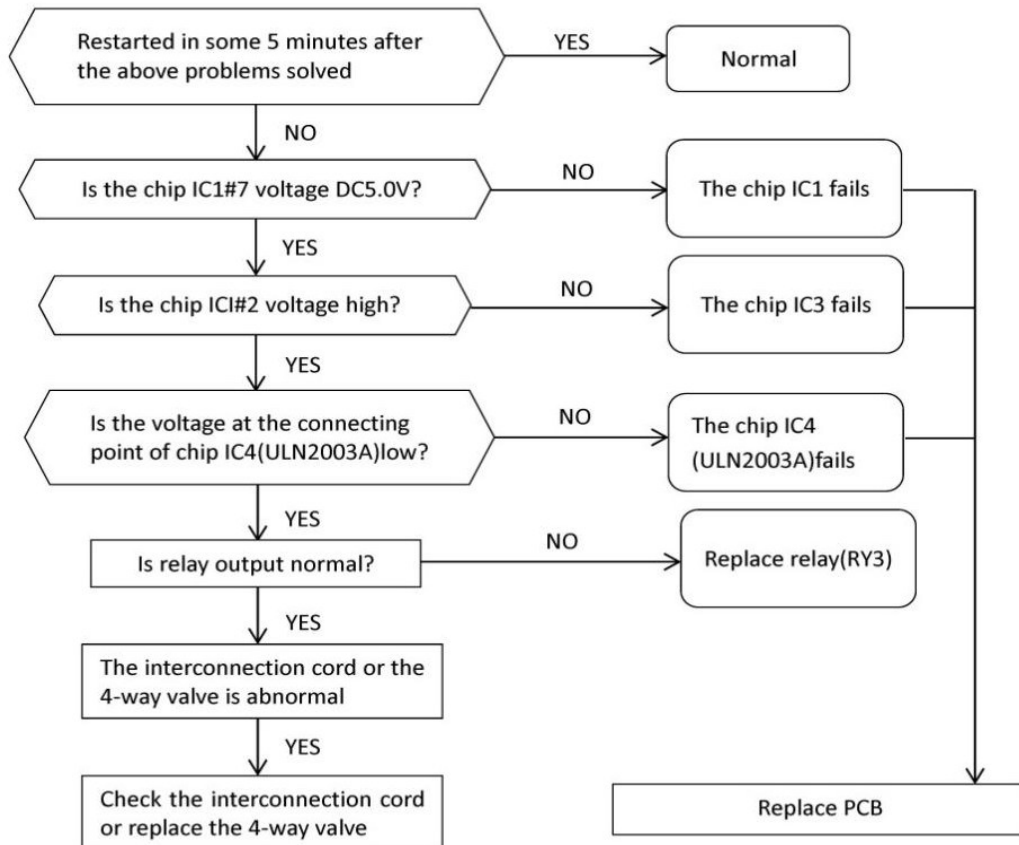

⑥ Remote Control Can Not Work

Trouble shooting procedure

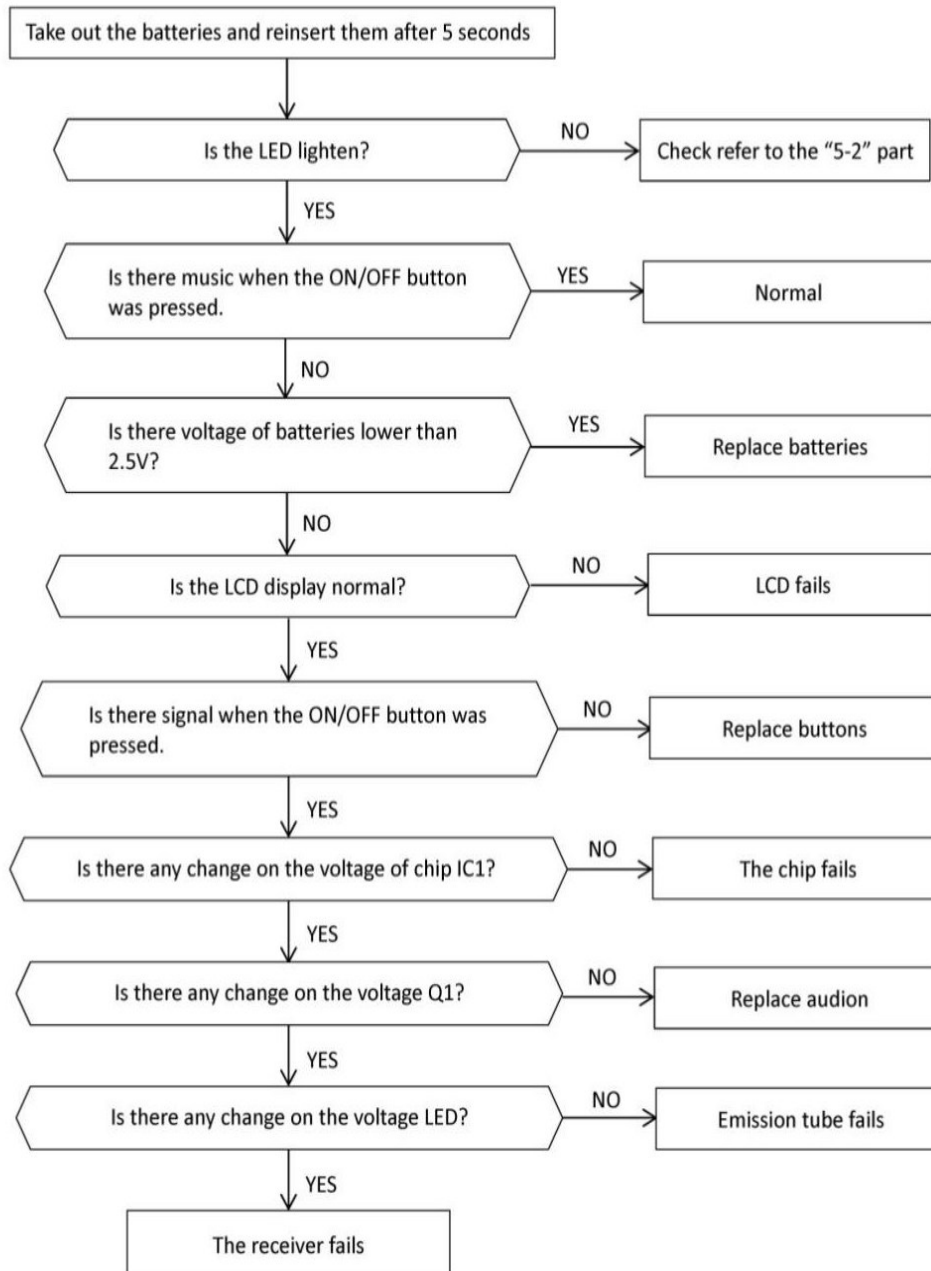

9. Removal Procedure

Stop operation of the air conditioner and remove the power cord before repairing the unit.

9-1 Indoor Unit

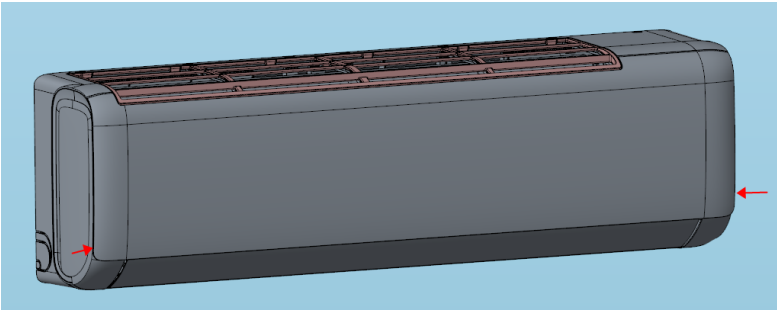
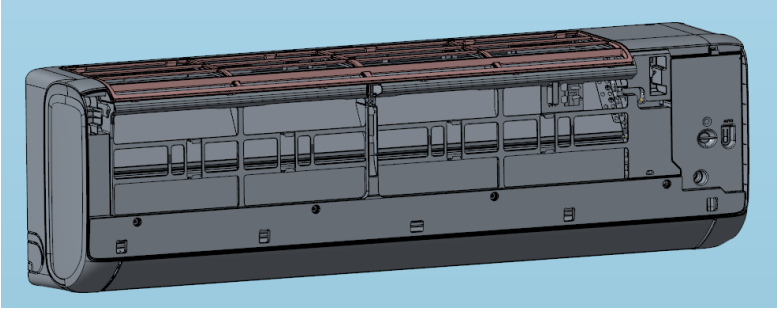
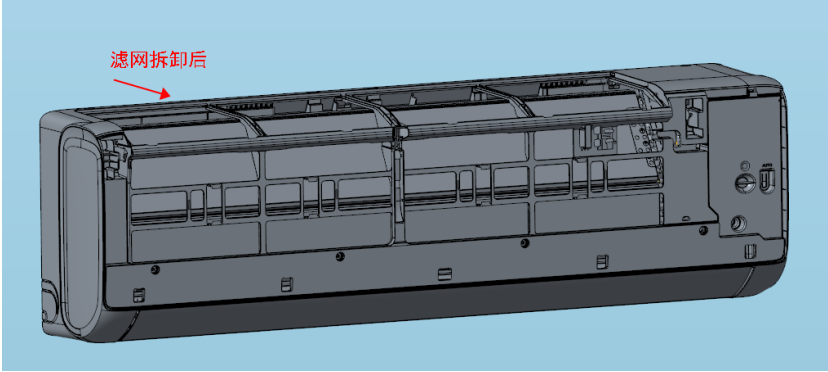
Part	Procedure	Diagram
1	1) Turn off the power, hold the middle panel with the middle finger, 2) open the panel upwards, remove the panel fixing shaft, and remove the panel.	
2	Remove front Panel	
3	Remove air filter	

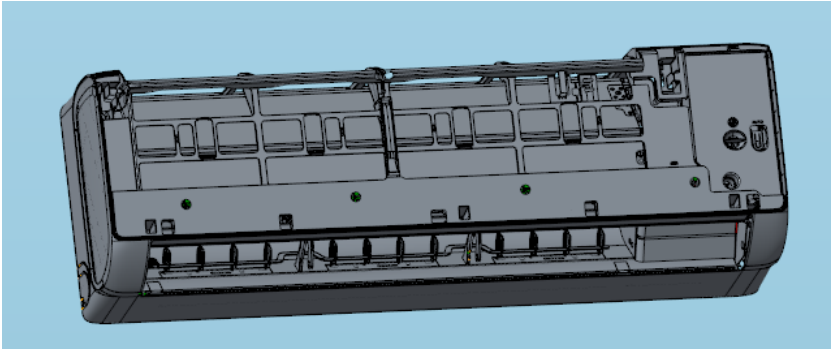
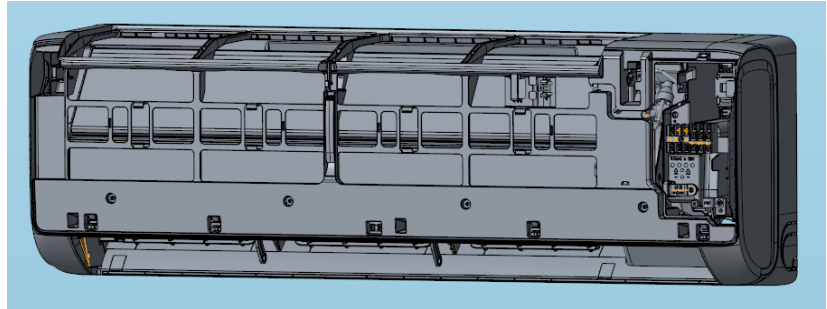
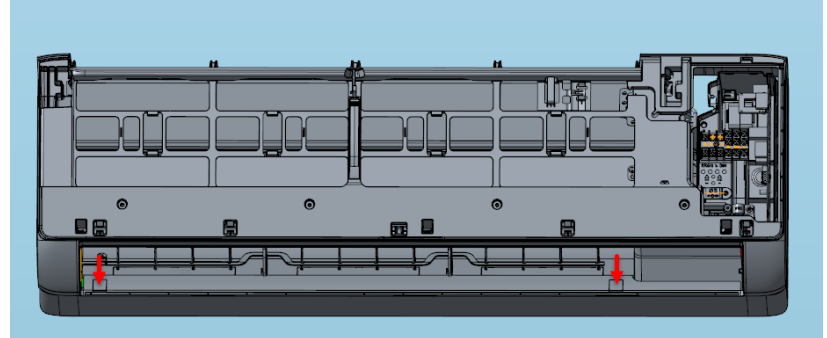
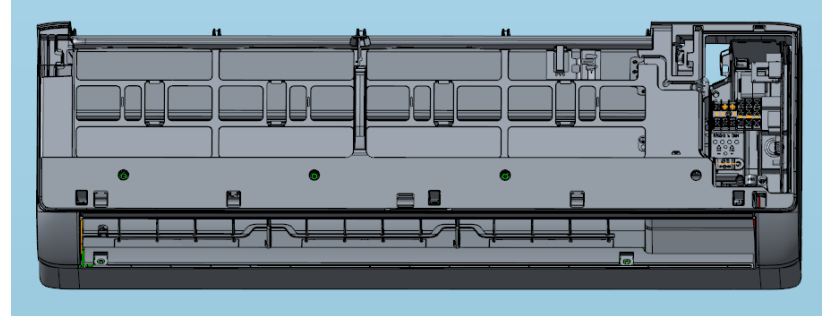
4	Remove air louver	
5	Remove medium frame cover	
6	Press down hard on the center frame screw cover	
7	Remove the two screw caps	

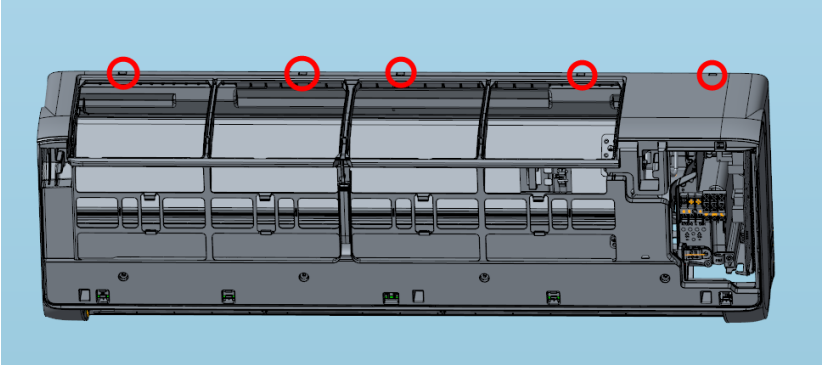
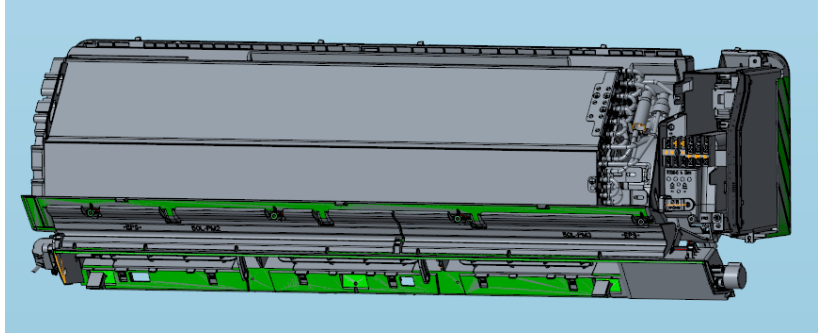
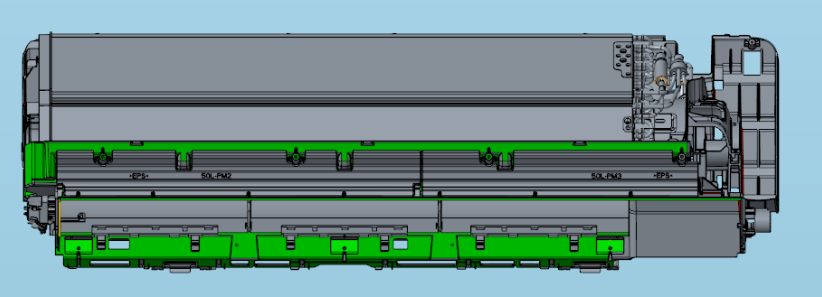
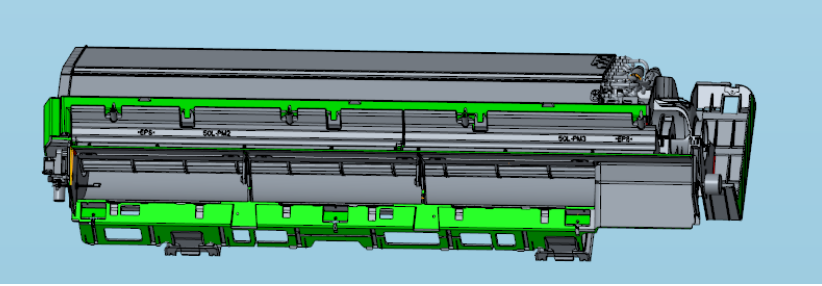
<p>8</p>	<p>Remove medium frame cover screw</p>	
<p>9</p>	<p>Remove medium frame</p>	
<p>10</p>	<p>Remove electric box</p>	
<p>11</p>	<p>Remove disassembly of guide vane and connecting rod</p>	

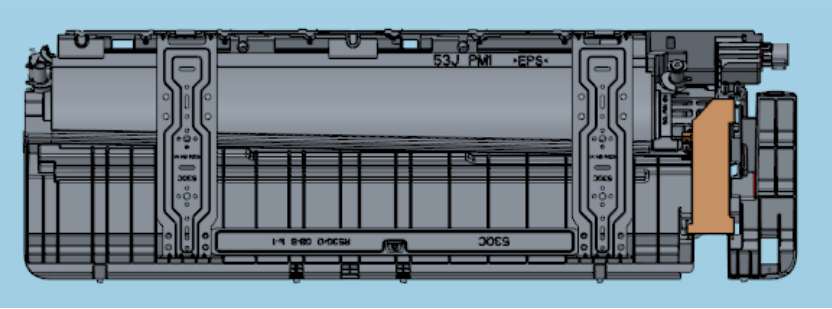
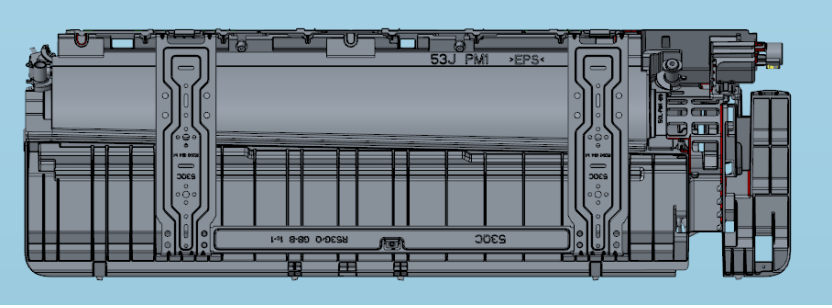
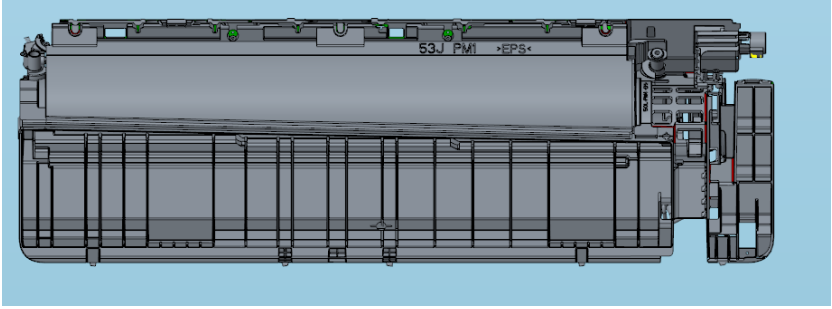
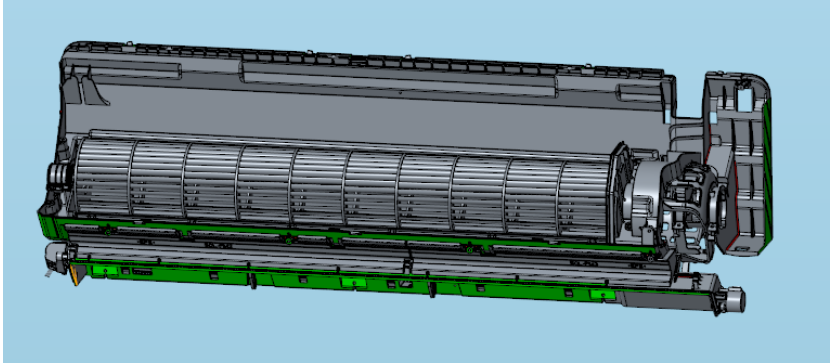
12	After removing disassembly of guide vane and connecting rod	
13	Remove pipe clamp	
14	Remove hanging plate	
15	Remove evaporator	

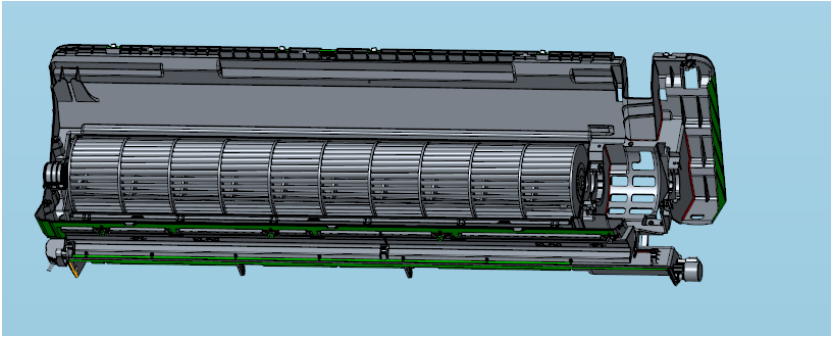
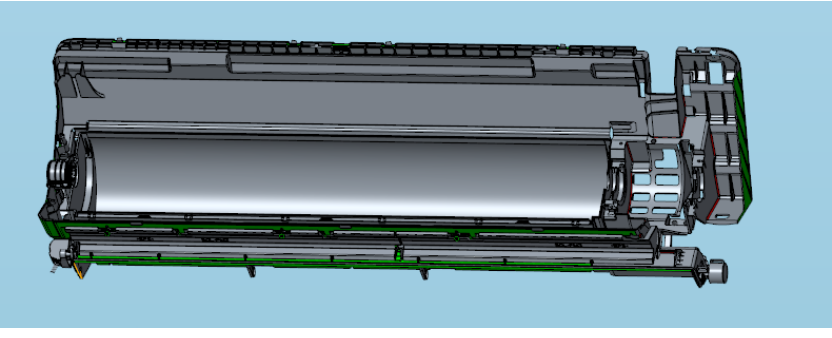
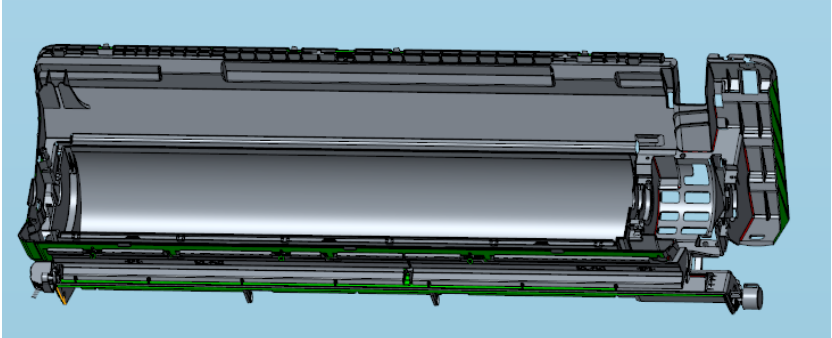
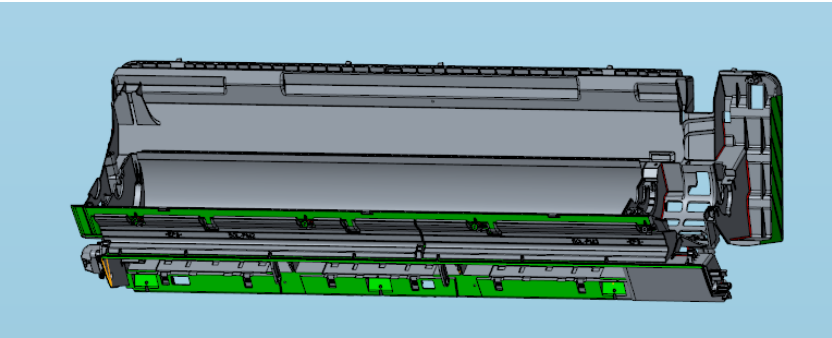
16	Remove motor	
17	Remove the blade	
18	Removal of bearing mounting	
19	Remove the stepper motor	

9-2 Outdoor Unit

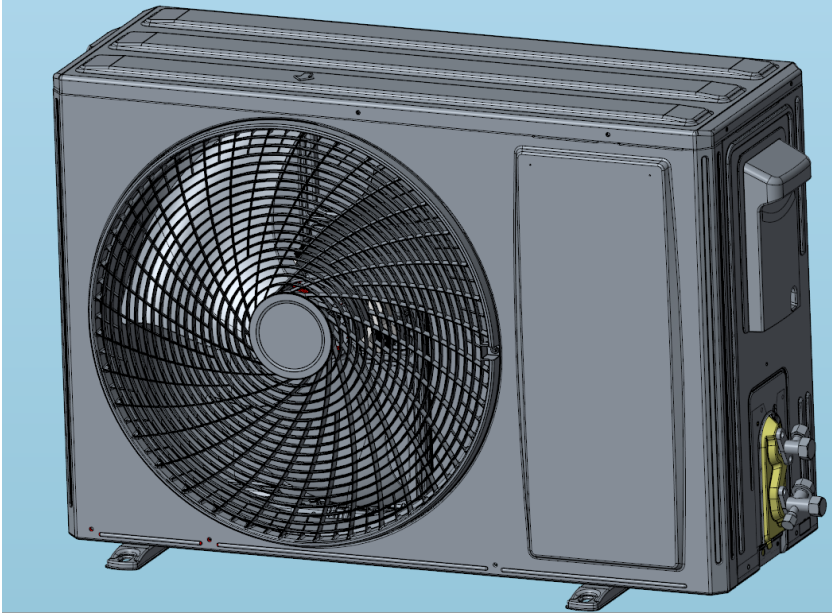
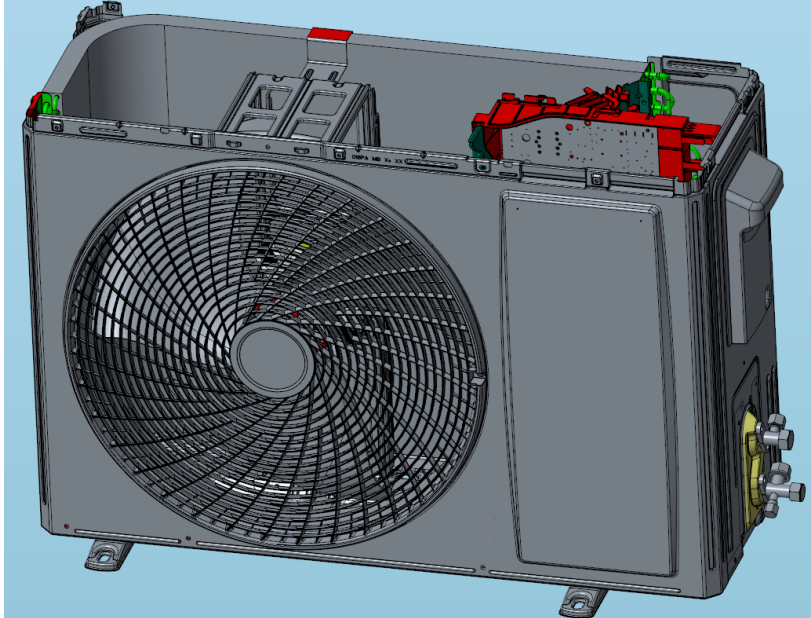
Part	Procedure	Diagram
1	Outdoor unit	 <p>A 3D perspective rendering of a grey outdoor air conditioning unit. The unit is rectangular with a large circular fan grille on the front. On the right side, there are service ports with yellow and white caps. The unit is mounted on two small feet at the bottom.</p>
2	Remove top cover	 <p>A 3D perspective rendering of the same outdoor unit, but with the top cover removed. The top cover is shown in red and green, revealing the internal components of the unit, including the compressor and fan assembly. The fan grille remains in place.</p>

3 Remove panel grille

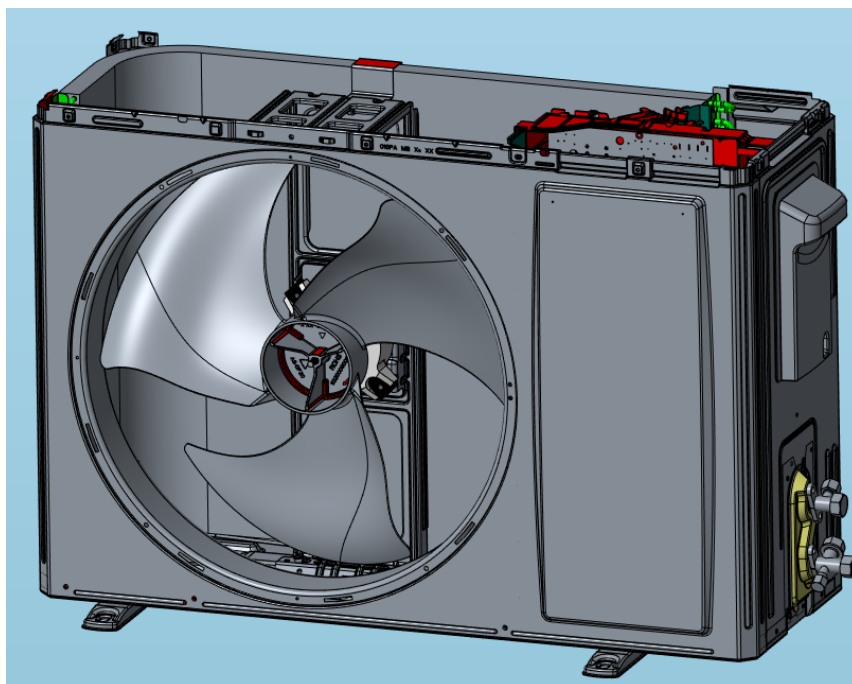

4 Remove front panel

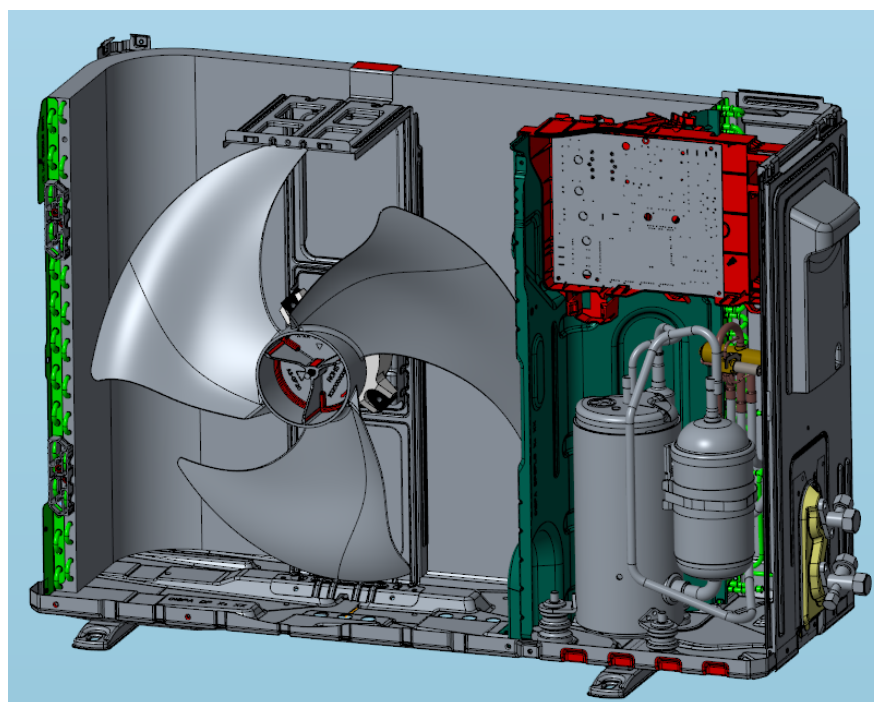

5 Remove E-part cover

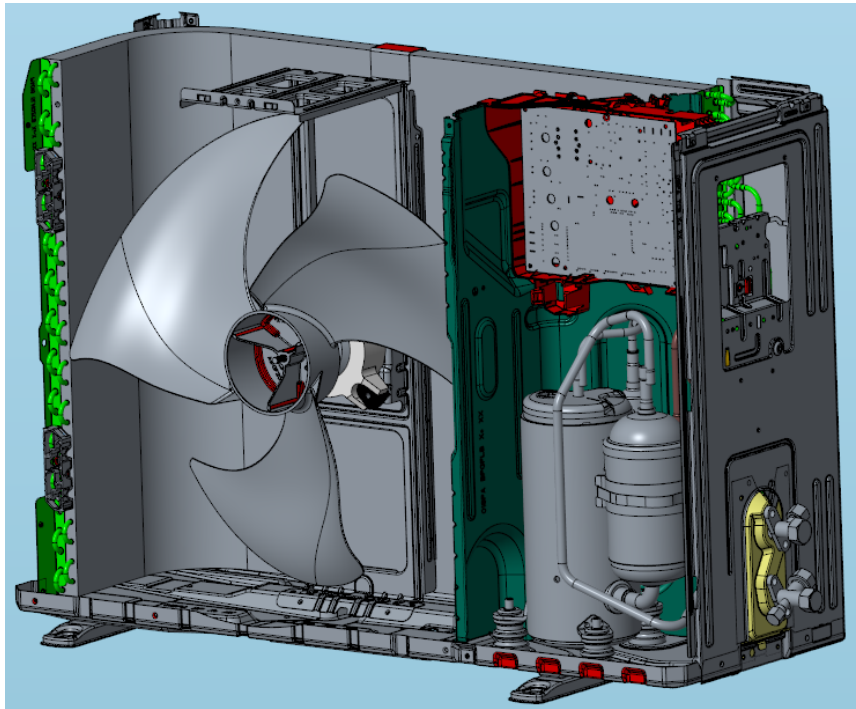

6 Remove right side panel

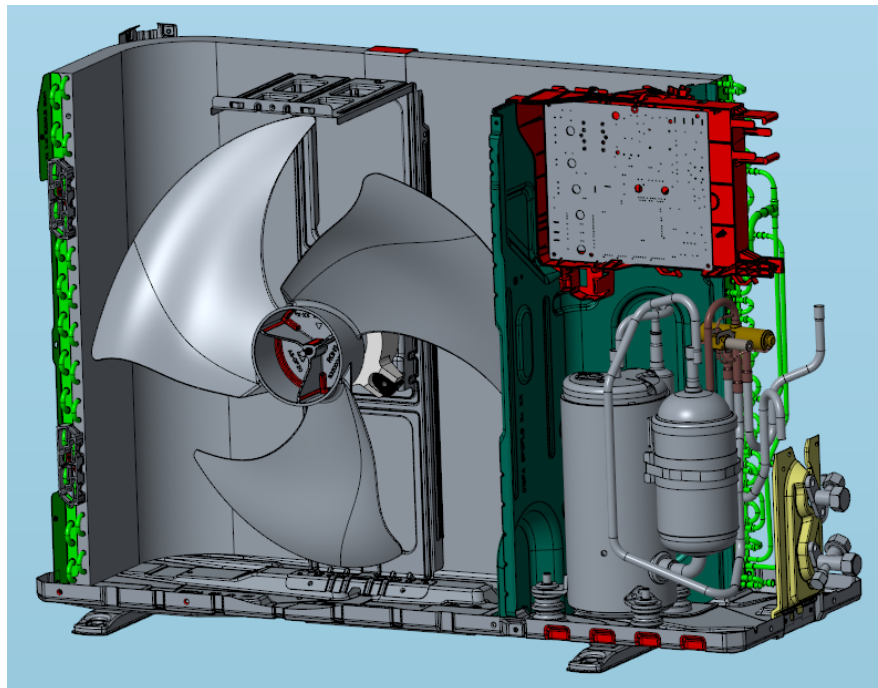

7

Remove axial flow blade

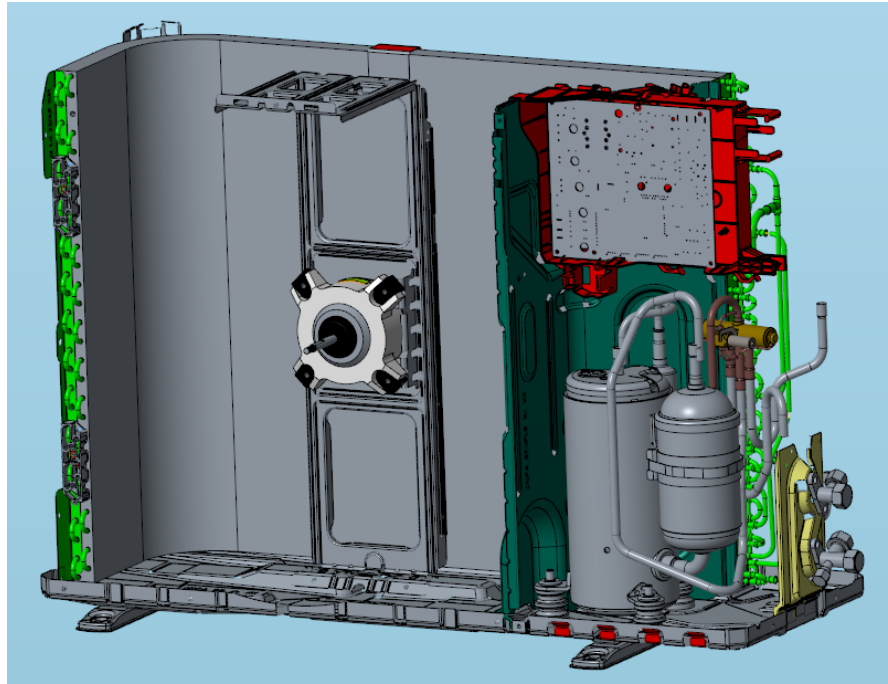

8

Remove outer motor

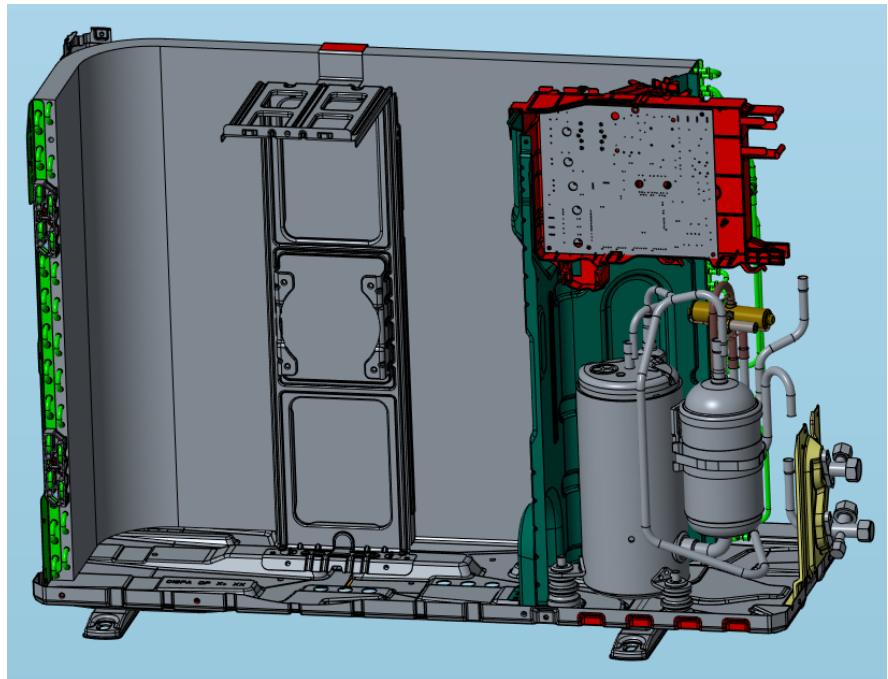

9 Remove electric box assembly

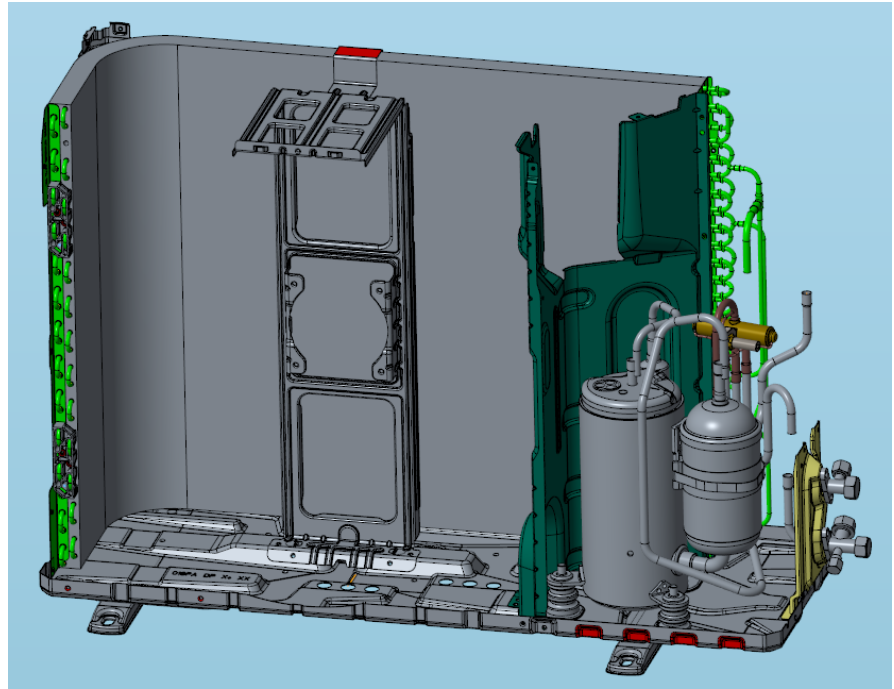

10 Remove motor support

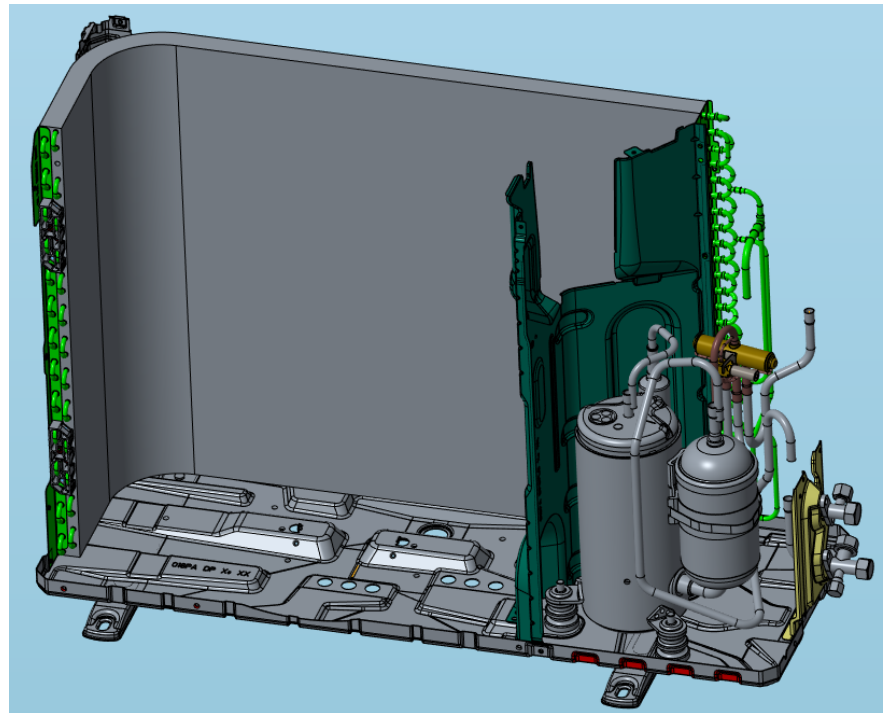

11

Remove partition board

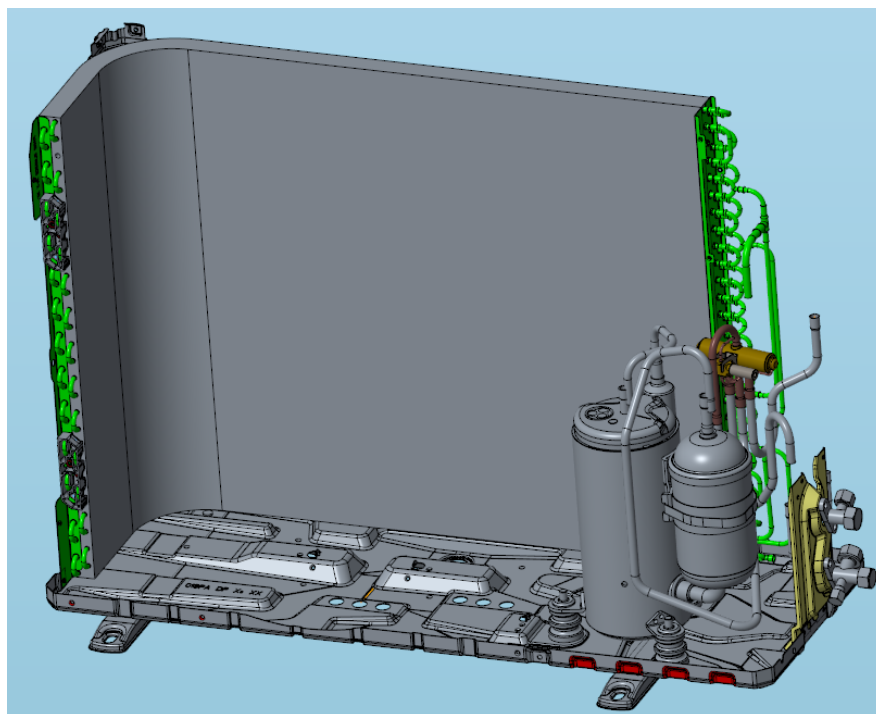

12

Remove left side support plate

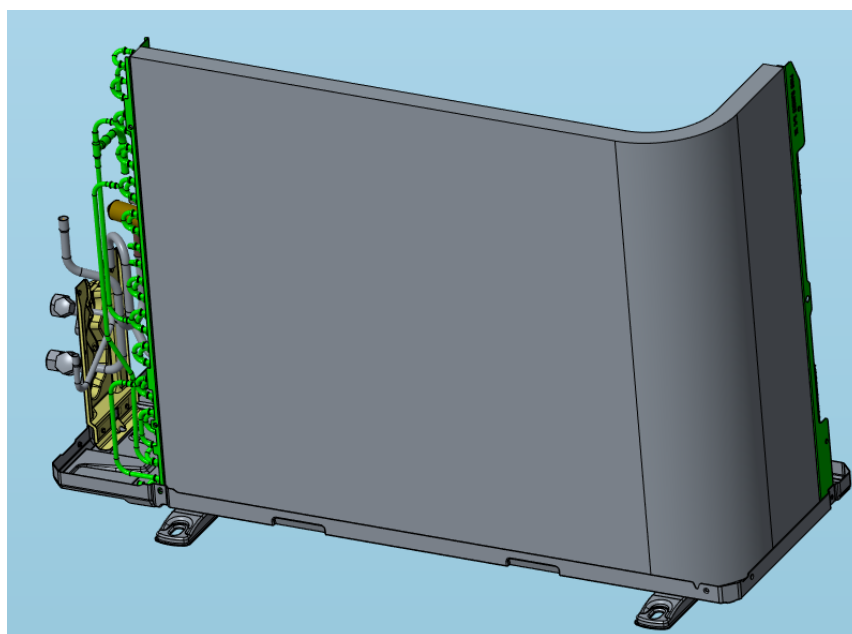

13

Remove pipeline assembly

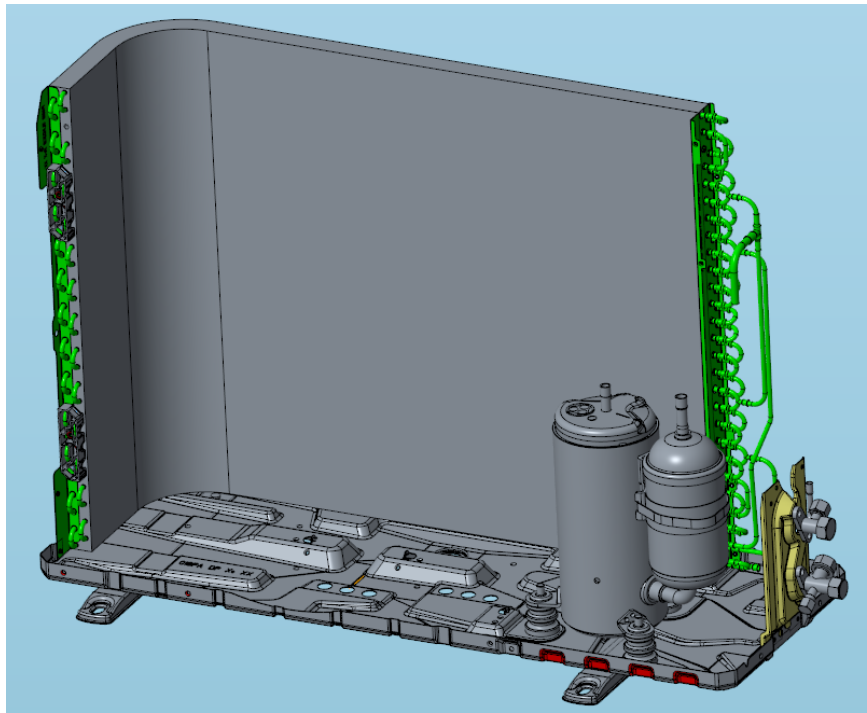

14

Remove stop valve assembly

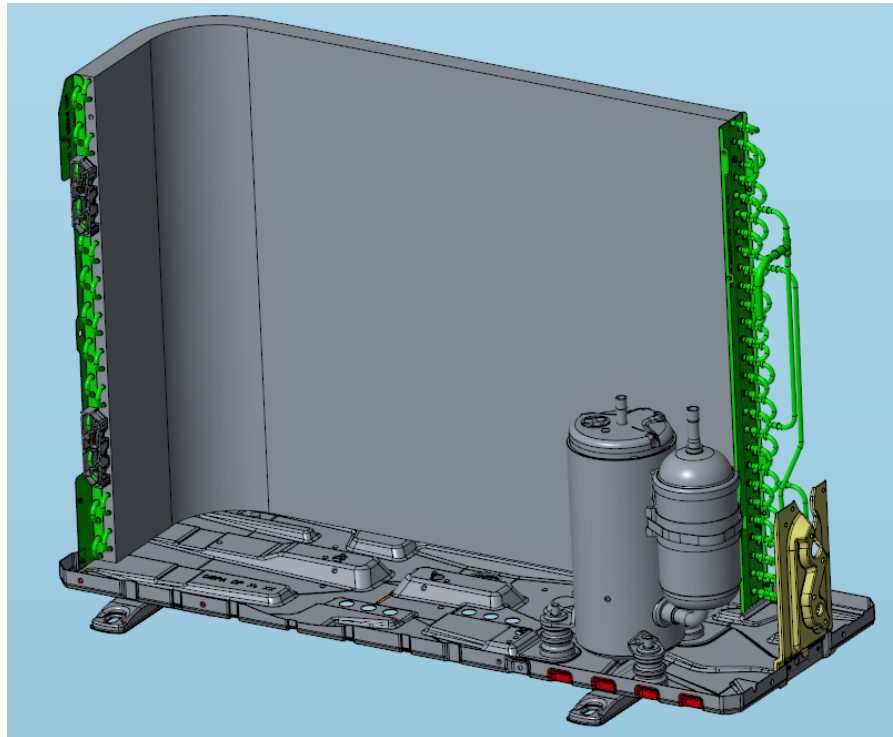

15 Remove valve plate

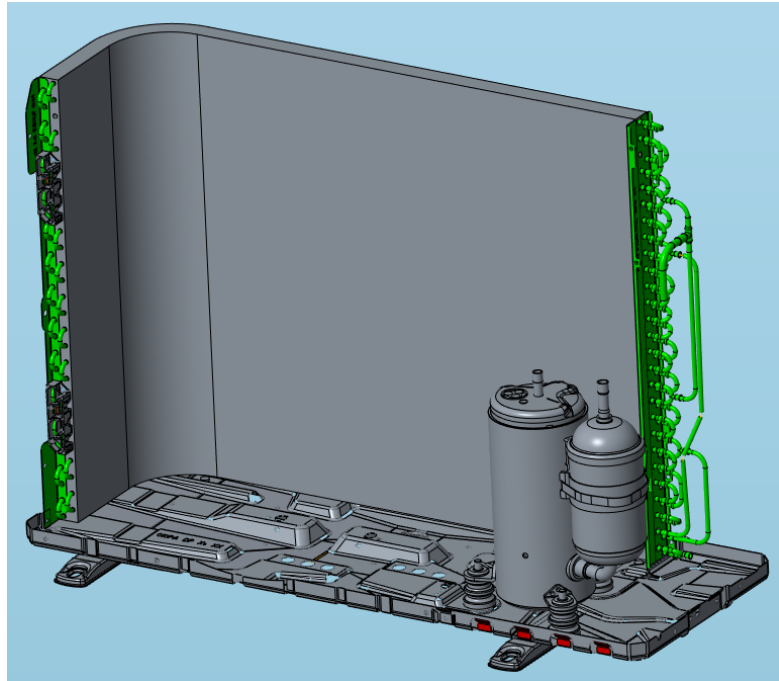

16 Remove compressor

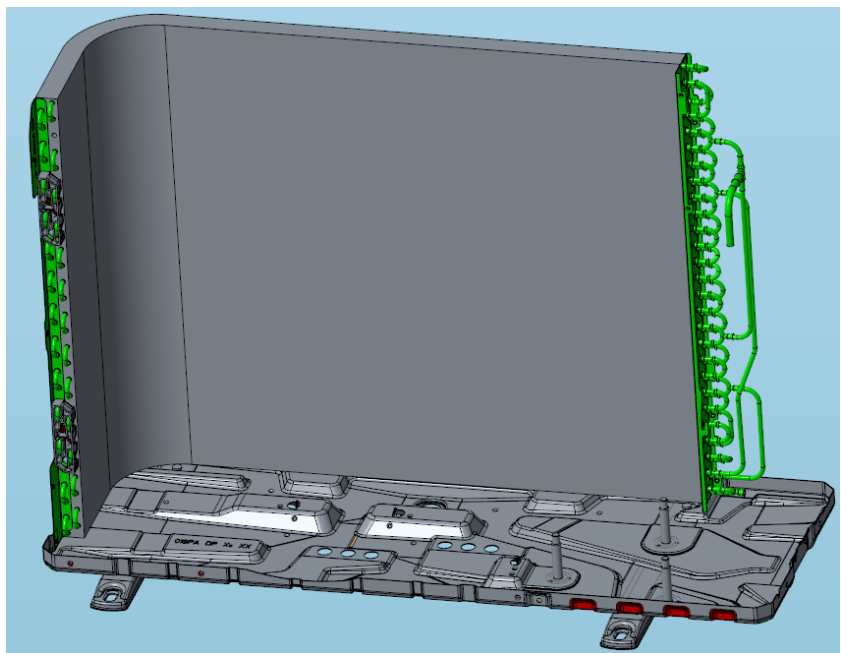

17

Remove
condenser

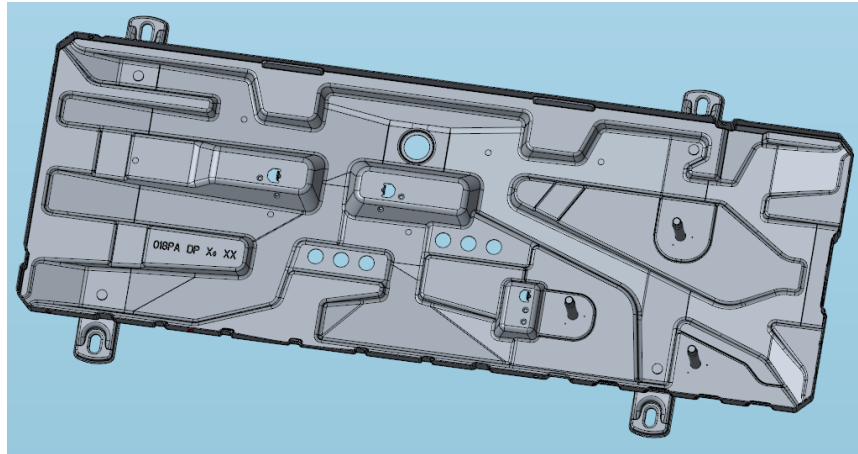



AZURI[®]



DELTRON[®]

A **BEIJER REF** Company

Split, Vukovarska 148
Tel: +385 (0)21 453 400
Fax: +385 (0)21 473 943
deltron@deltron.hr

Zagreb, Zagrebačka avenija 104
Tel: +385 (0)1 60 64 777
Fax: +385 (0)1 60 64 778
deltron.zagreb@deltron.hr

Sarajevo, Pijačna 14k, 71000
Tel: +387 (0) 33 840 200
Fax: +387 (0) 33 840 203
deltron.sarajevo@deltron.ba

DISTRIBUTOR



www.deltron.hr